



wheel-mounted
for drums 20/220 kg



Art. 42050 (20/60 kg)

Art. 42000 (180/220 kg)

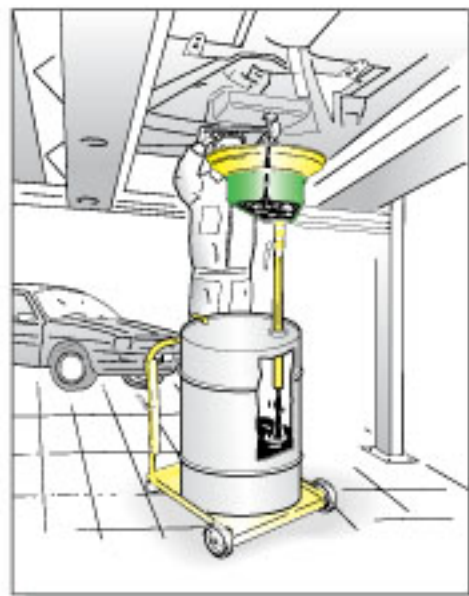

Wheel-mounted **oil drainers** for container of various types, tanks and drums of all sizes up to 220 kg. Practical and functional, suitable for gravity draining of engine, gearbox and differential oil from all motor vehicles placed on auto lift or pit. The height-adjustable collection **bowl** (capacity 13 litres) is mounted on a swivel joint facilitating optimal positioning for work.

Art. 42050 **Waste oil drainer** for tanks or drums composed of:
art. 80050 Trolley for 20/60 kg containers
collection bowl with oversize funnel
antislash screen/filter

N° 2 packing m³ 0,120 kg 17

Art. 42000 **Waste oil drainer** for drums composed of:
art. 80200 Trolley for 180/220 kg drums
collection bowl with oversize funnel
antislash screen/filter
drum clamping ring

N° 2 packing m³ 0,150 kg 29

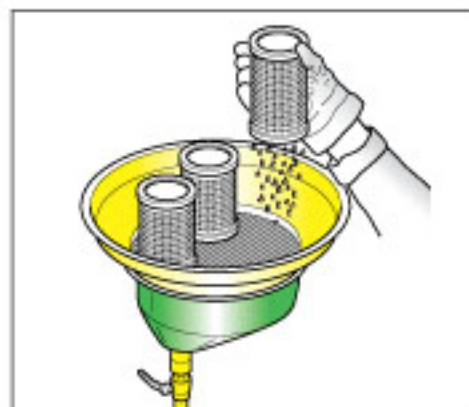

In addition to serving as a filter, the antislash screen is also a useful support for draining the filters just changed.

Article	42050	42000
Trolley capacity	20/60 Kg	180/220 Kg
Bowl capacity	13 lt	13 lt
Diameter oversize funnel	580 mm	580 mm
Maximum height	1800 mm	1800 mm
Minimum height	1200 mm	1300 mm

Overall dimensions



art. 42050

art. 42000

Warning: Do not use flammable or corrosive liquids.

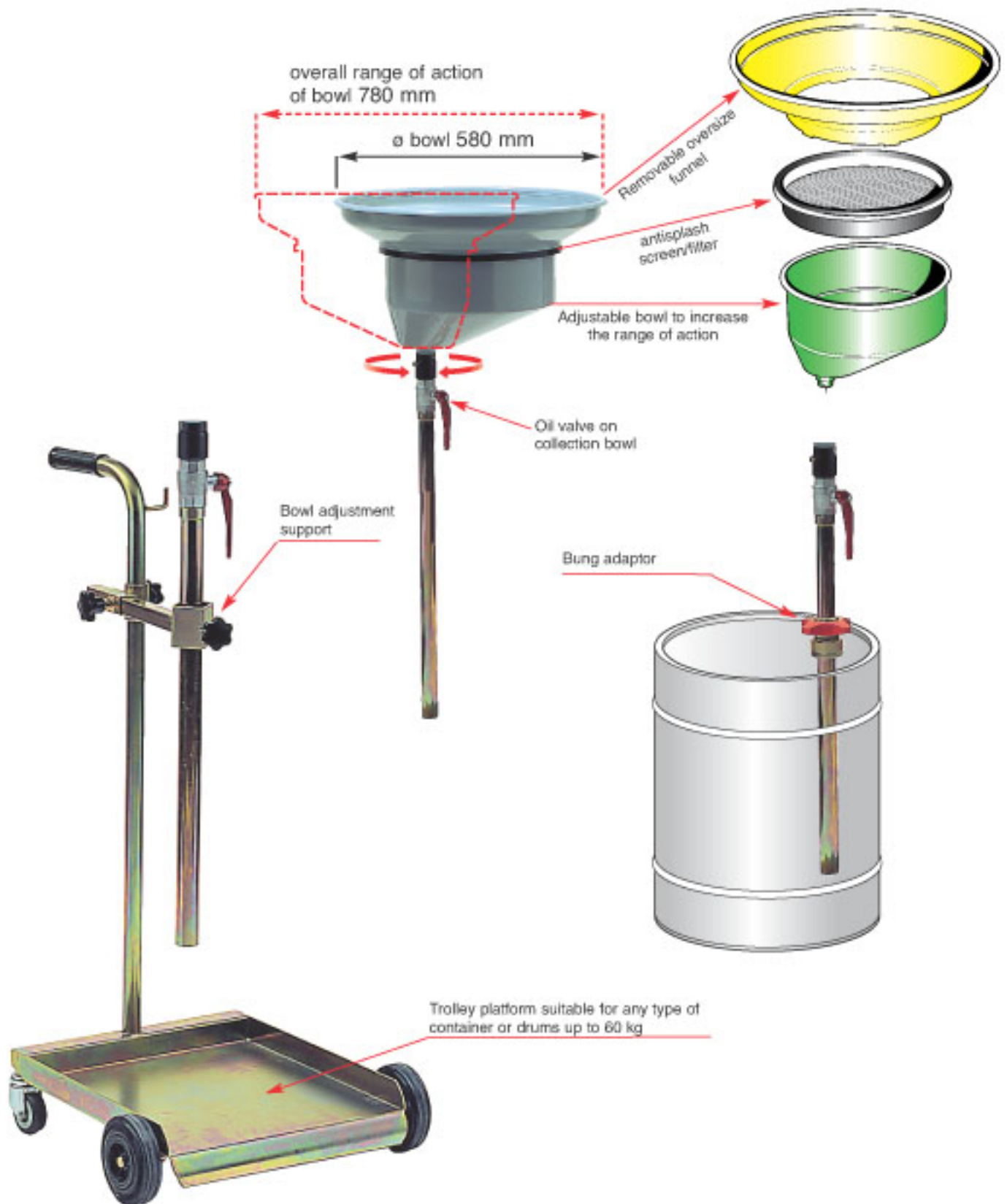

with **CENTRAL** bowl

Oil drainer with wheel-mounted tank: practical and functional, suitable for gravity draining of engine, gearbox and differential oil from all motor vehicles placed on auto lift or pit.

The centrally mounted 13-litre capacity **bowl**, in addition to being height-adjustable, can be optimally positioned thanks to the swivel joint on which it is applied.

Art. 42065 Waste oil drainer with wheel-mounted 65-litre tank equipped with level-gauge height-adjustable collection bowl with oversize funnel antispash screen/filter and removable tool tray

N° 2 packing m^3 0,270 kg 33

Art. 42090 Waste oil drainer with wheel-mounted 90-litre tank equipped with level-gauge height-adjustable collection bowl with oversize funnel antispash screen/filter and removable tool tray

N° 2 packing m^3 0,300 kg 34

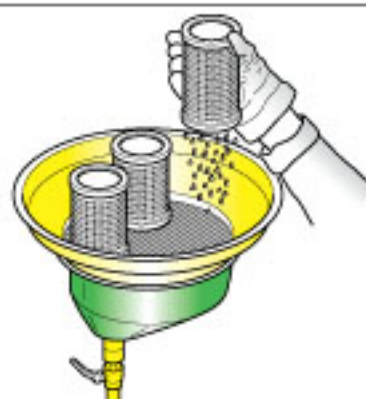

In addition to serving as a filter, the antispash screen is also a useful support for draining the filters just changed.

Article	42065	42090
Tank capacity	65 lt	90 lt
Max. collection capacity	52 lt	75 lt
Bowl capacity	13 lt	13 lt
Diameter oversize funnel	ø 580 mm	ø 580 mm
Length draining hose	2 m	2 m
Maximum height	1780 mm	1900 mm
Minimum height	1270 mm	1400 mm
Draining pressure	0,5 bar	0,5 bar

Warning: Do not use flammable or corrosive liquids.

Overall dimensions

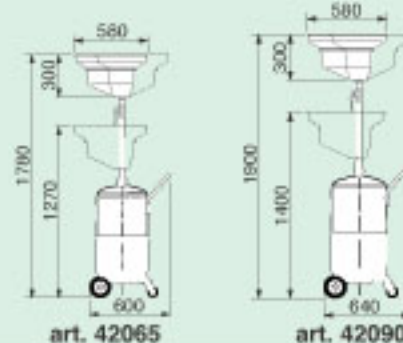

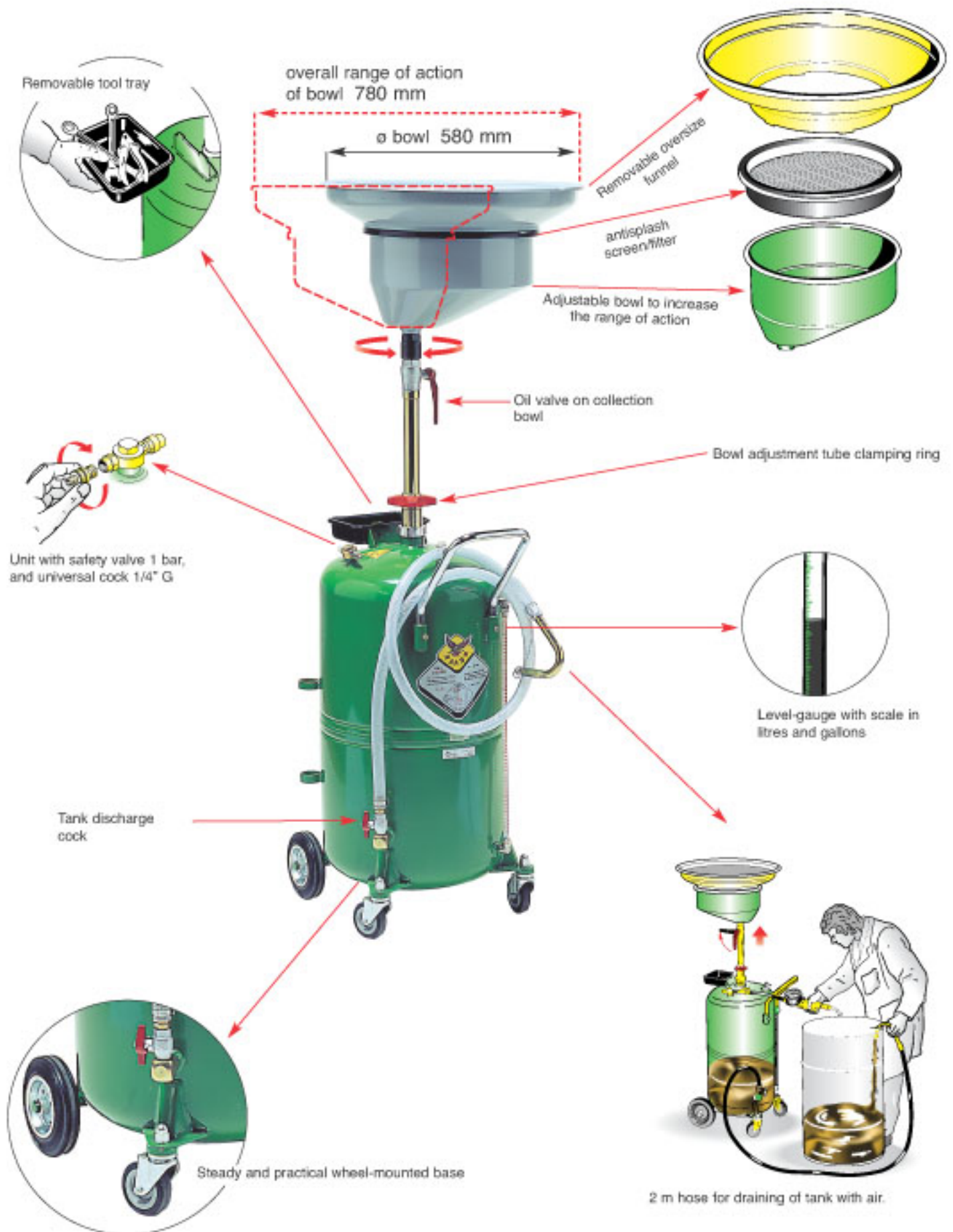

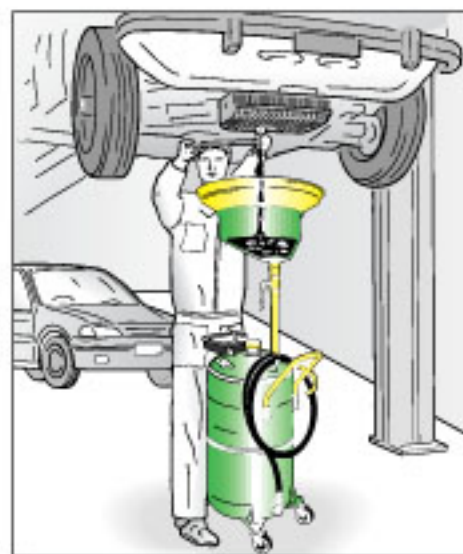
with **SIDE** bowl

Waste oil drainer with wheel-mounted tank: **practical and functional**, suitable for gravity draining of engine, gearbox and differential oil from all motor vehicles placed on auto lift or pit. The 13-litre capacity **bowl** is side-mounted, enabling use even in difficult situations. It is also height adjustable and equipped with swivel joint enabling optimum positioning.

Art. 42066 Waste oil drainers with side bowl and 65-litre wheel-mounted tank equipped with level-gauge height-adjustable collection bowl with oversize funnel antispash screen/filter and removable tool tray.

📦 N° 2 packing m³ 0,270 🏺 kg 33

Art. 42091 Waste oil drainers with side bowl and 90-litre wheel-mounted tank equipped with level-gauge height-adjustable collection bowl with oversize funnel antispash screen/filter and removable tool tray.

📦 N° 2 packing m³ 0,300 🏺 kg 34



The minimum bowl height allows the motor vehicle to be positioned at a height enabling oil draining as well as other maintenance operations.

Article	42066	42091
Tank capacity	65 lt	90 lt
Max. collection capacity	52 lt	75 lt
Bowl capacity	13 lt	13 lt
Diameter oversize funnel	ø 580 mm	ø 580 mm
Length draining hose	2 m	2 m
Maximum height	1750 mm	1700 mm
Minimum height	1340 mm	1250 mm
Draining pressure	0,5 bar	0,5 bar

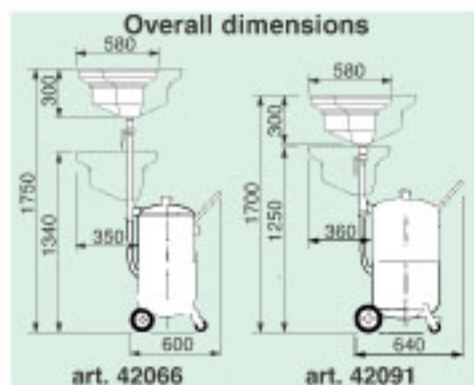

Warning: Do not use flammable or corrosive liquids.

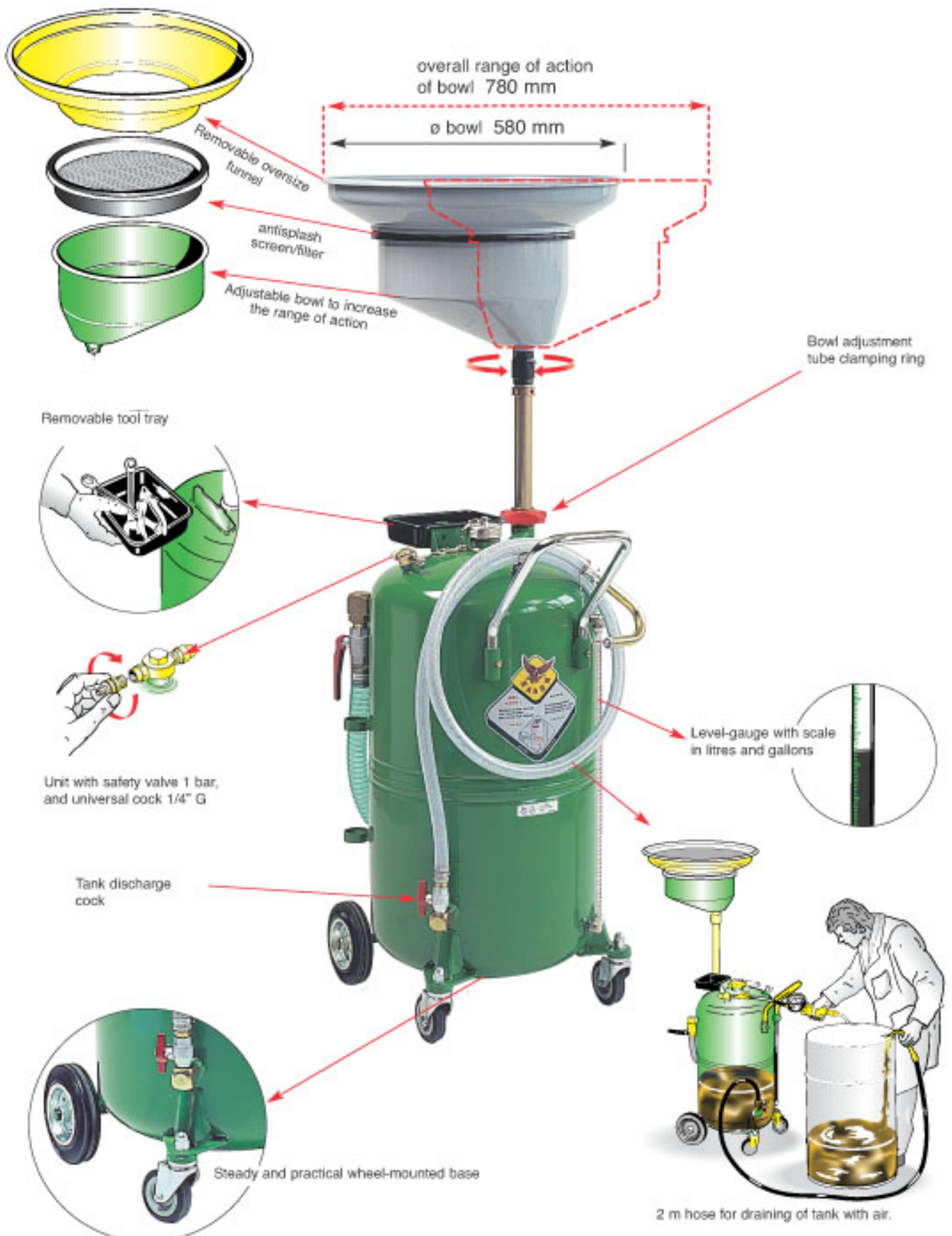



for PITS

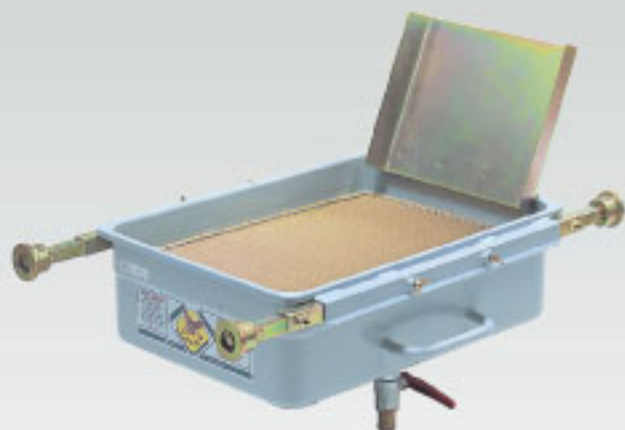

Art. 42060 65lt

Art. 42060 Waste oil drainers for pits

N° 1 packing m³ 0,140 kg 27,1

Article	42060
Capacity	65 lt
Discharge hole	male 1" G.

Warning: Do not use flammable or corrosive liquids.

Transfer of the drained oil can be by gravity directly into the tank or by suction by conveying the oil to the tank by means of pump art.33125 situated on the fixed system.

Art. 33125 Wall kit for emptying tanks

see page 67

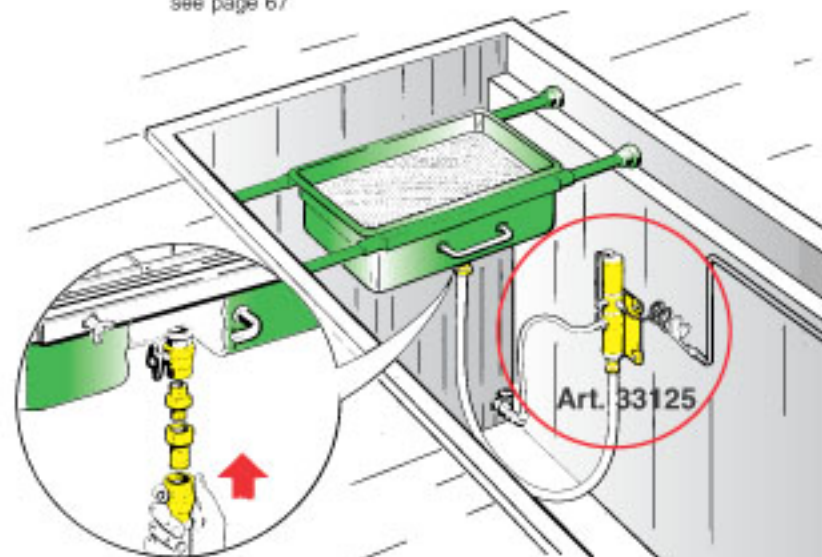

Possibility of applying connections (quick-connector art. 33126-33127) to connect the tank to a pump art. 33125.

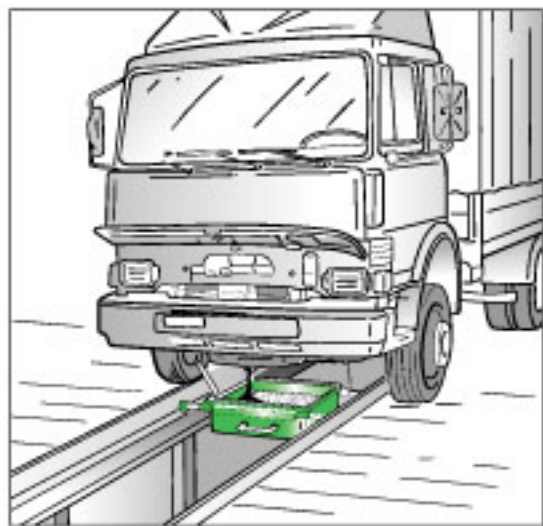

Pit oil drainer, suitable for gravity draining of engine, gearbox and differential oil from all motor vehicles placed on a pit. The tank has an antispash screen which can also be used as a support for draining the oil filters. The wheel-mounted supports used to handle the tank are adjustable. The 65-litre tank is equipped with a removable side oil conveyor.

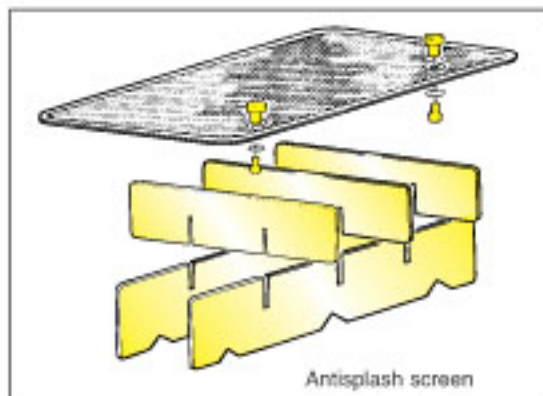

Antispash screen

Overall dimensions

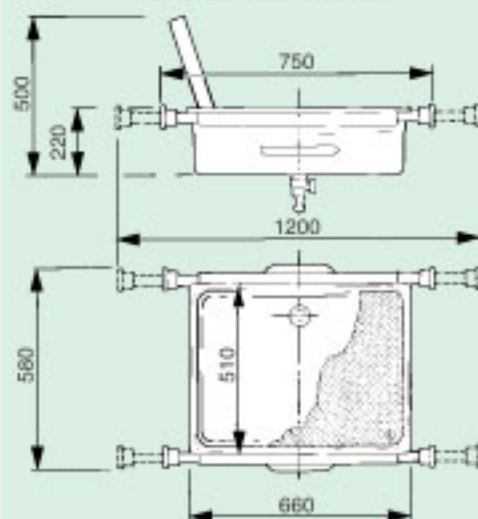

art. 42060

FLOOR MOUNTED



Art. 42070 50lt

Art. 42070 Floor-mounted waste oil drainer for trucks, tank capacity 50 litres

N° 1 packing m³ 0,136 kg 18,8

Article	42070
Capacity	50 lt
Casters	4 x ø 80
Discharge tube	incorporated

Warning: Do not use flammable or corrosive liquids.

Transfer of the drained oil can be done by suction with any suction unit, the suction probe, or else by conveying the oil to the tank by means of wall kit art.33125 situated on the fixed system.

Art. 33125 Wall kit for emptying tanks
see page 67

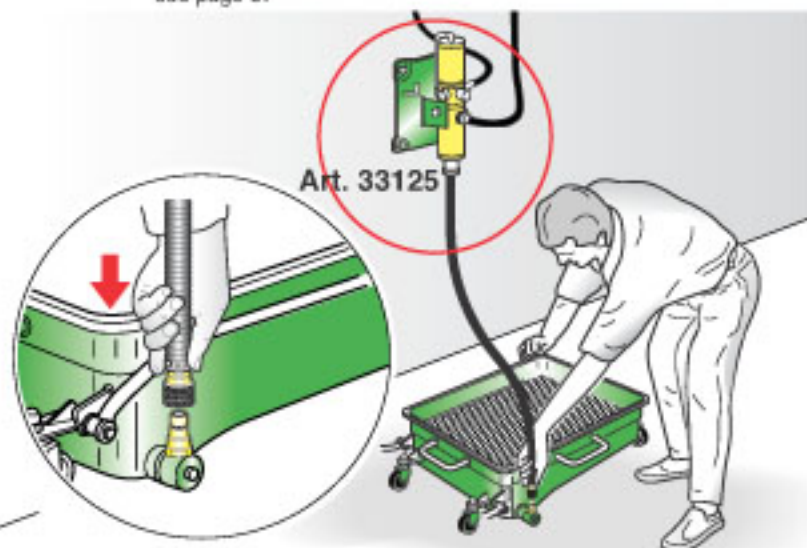

Possibility of applying connections (quick-connector art. 33126-33127) to connect the tank to a pump art. 33125.



Floor-mounted oil drainer, wheel-mounted, suitable for gravity draining of engine, gearbox and differential oil from all motor vehicles even if not placed on auto lift or pit. The 50-litre capacity collection tank is equipped with an antispash screen which can also be used as a support.

