



## STANDARD



Art. 44060 65lt



Art. 44090 90lt

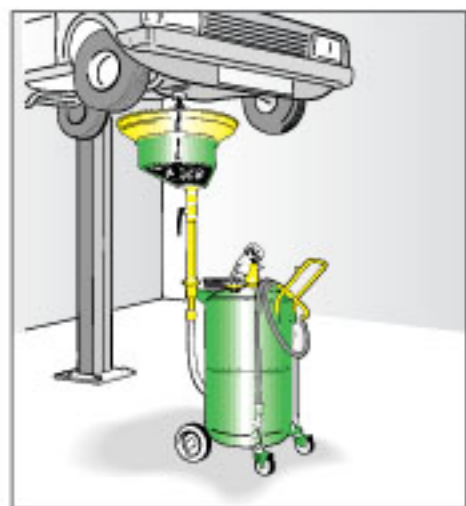

The combination oil suction/drainers are suitable for draining the engine oil from any motor vehicle by gravity, (with vehicles placed on auto lift or pit) and with probe.

Handy for draining over 8 litres, e.g. for trucks, tractors, heavy motor vehicles.

The oil must be hot (70/80 °C).

Art. 44060 **Combination oil suction/drainer** with wheel-mounted 65-litre tank, equipped with level-gauge removable tool tray supplied with series of probes (art. 45560) See page 122

N° 3 packing  $m^3$  0,330 kg 34,6

Art. 44090 **Combination oil suction/drainer** with wheel-mounted 90-litre tank, equipped with level-gauge removable tool tray supplied with series of probes (art. 45560) See page 122

N° 3 packing  $m^3$  0,360 kg 38,2

Article	44060	44090
Tank capacity	65 lt	90 lt
Max. draining capacity	52 lt	75 lt
Bowl capacity	13 lt	13 lt
Depressurizing pressure	7 bar	7 bar
Depressurization time	2 min	2,5-3 min
Noise level	75 dB	75 dB
Suction speed	1,5-2 lt/min	1,5-2 lt/min
with oil at 70-80°C, probes 6 mm.		
Total suction capacity	43-45 lt	60-65 lt
Suction hose	2 m	2 m
Draining hose	2 m	2 m
Max. discharge pressure	0,5 bar	0,5 bar

**Important:** DO NOT drain brake fluids, fuels or flammable liquids of any kind, corrosive liquids.

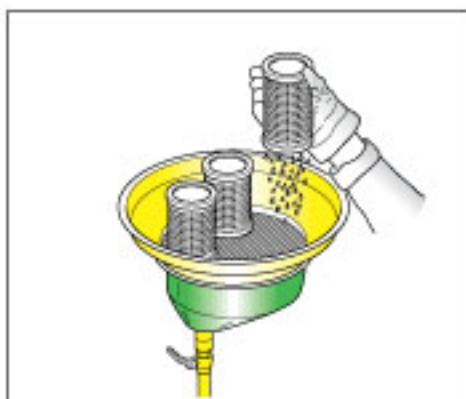

In addition to serving as a filter, the antispash screen is also a useful support for draining the filters just changed.

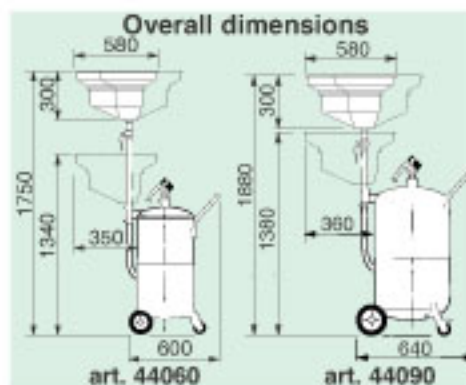

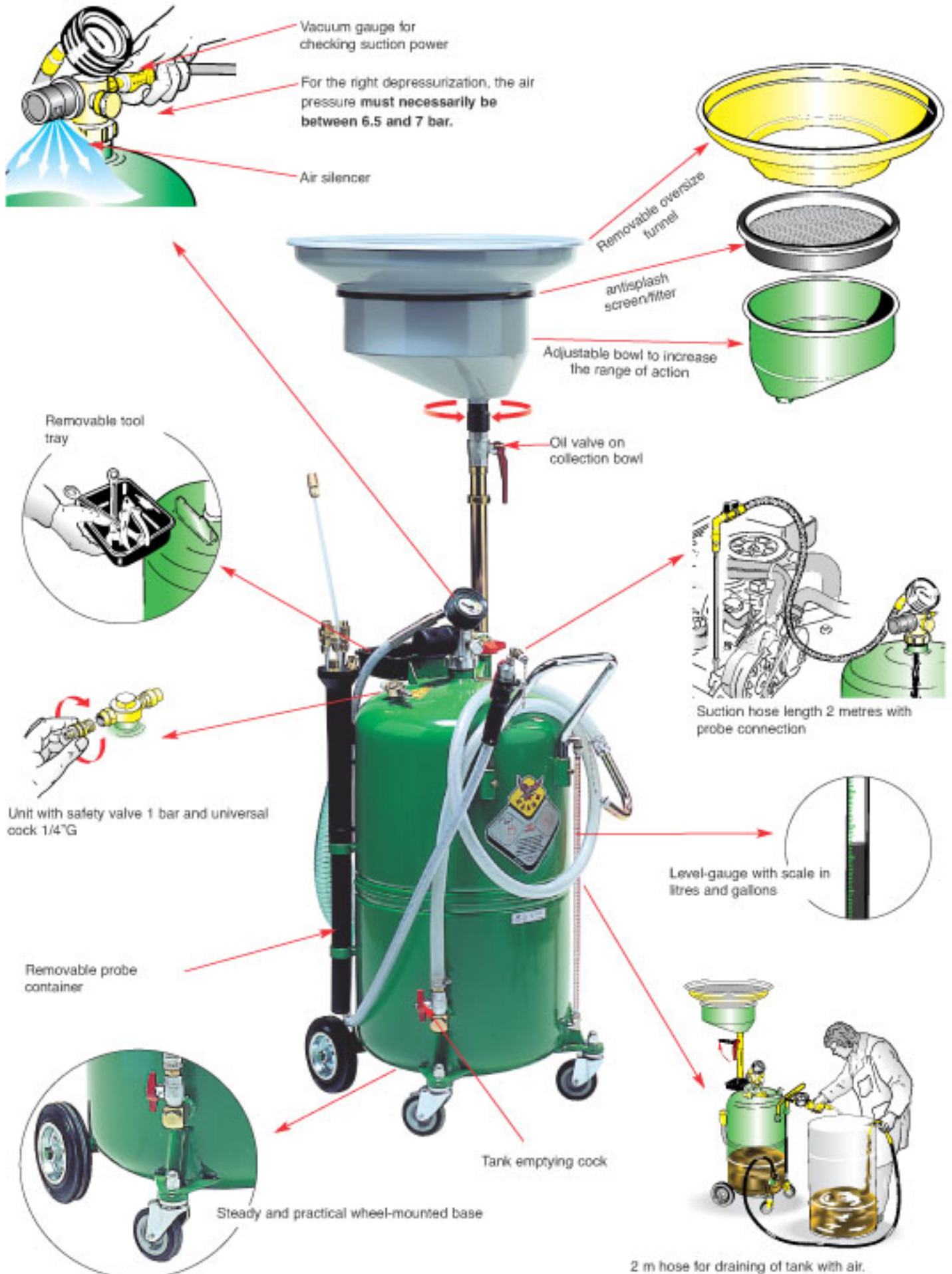



with CHAMBER



Art. 44065 65lt



Art. 44091 90lt



The combination oil suction/drainers are suitable for draining the engine oil from any motor vehicle by gravity, (with vehicles placed on auto lift or pit) and with probe.

The transparent chamber allows the quantity and quality of the sucked oil to be controlled immediately. The oil must be hot (70/80 °C).

Art. 44065 **Combination waste oil suction/drainer with transparent chamber** wheel-mounted **65-litre tank** equipped with level-gauge supplied with series of probes (art. 45560) See page 122

☐ N° 3 packing m<sup>3</sup> 0,330 📦 kg 38,2

Art. 44091 **Combination waste oil suction/drainer with transparent chamber** wheel-mounted **90-litre tank** equipped with level-gauge supplied with series of probes (art. 45560) See page 122

☐ N° 3 packing m<sup>3</sup> 0,360 📦 kg 42,1

Article	44065	44091
Tank capacity	65 lt	90 lt
Max. draining capacity	52 lt	75 lt
Chamber capacity	8 lt	8 lt
Bowl capacity	13 lt	13 lt
Depressurizing pressure	7 bar	7 bar
Depressurization time	2 min	2,5-3 min
Noise level	75 dB	75 dB
Suction speed	1,5-2 lt/min	1,5-2 lt/min
with oil at 70-80°C, probes 6 mm.		
Total suction capacity	43-45 lt	60-65 lt
Suction hose	2 m	2 m
Draining hose	2 m	2 m
Max. discharge pressure	0,5 bar	0,5 bar

**Important:** DO NOT drain brake fluids, fuels or flammable liquids of any kind, corrosive liquids.

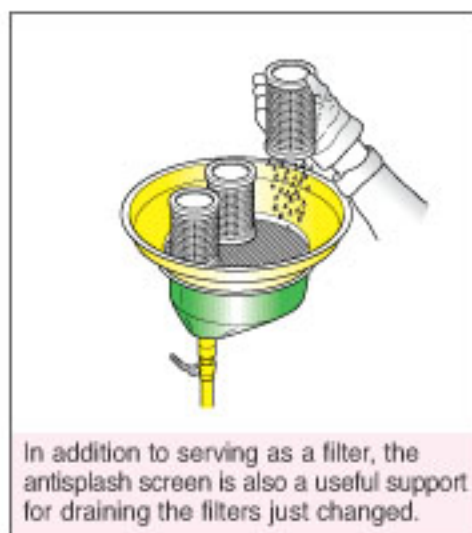

In addition to serving as a filter, the anti-splash screen is also a useful support for draining the filters just changed.

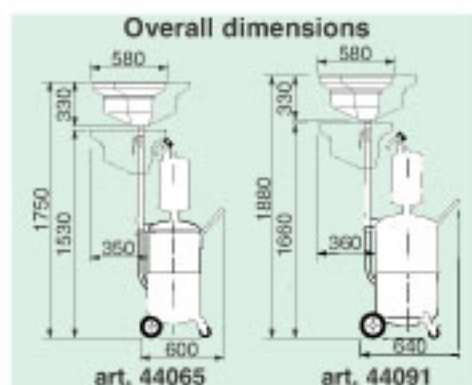

art. 44065

art. 44091

