





RAASM offers a **series of pumps** each intended for a specific type of use.



When choosing a pump, it is important to take into consideration the following **fundamental elements**:

- **type of fluid** to be delivered,
- **density or viscosity of the fluid** to be delivered,
- **quantity of fluid** to be delivered,
- **distance** from pump to delivery point,
- **pressure** of fluid for type of use.

PUMP SERIES 1:1/23

Ratio 1:1
Capacity 23 l/min

PUMP SERIES 1:1/40

Ratio 1:1
Capacity 40 l/min



The indicative table given below, will help you choose the right pump for your needs.

TYPE of FLUID to be used	TYPE of USE of fluid	RANGE OF PUMPS suitable for the desired fluid
Low-viscosity fluids such as: oils of various viscosities (SAE 15/20), hydraulic fluid, antifreeze, Diesel fuel and allied products, etc.	Fluid transfer max 23 l/min for short distances (5/10 metres), at low pressure (max 8 bar)	Pump series 1:1/23 Ratio 1:1 relative capacity 23 l/min see page 64
Low-viscosity fluids such as: oils of various viscosities (SAE 15/20), hydraulic fluid, antifreeze, Diesel fuel and allied products, etc.	Fluid transfer max 40 l/min for short and medium distances (15/20 metres), at low pressure (max 8/10 bar)	Pump series 1:1/40 Ratio 1:1 relative capacity 40 l/min see page 65
Low and medium viscosity fluids such as: oils of various viscosities (SAE 15/50), hydraulic fluid, antifreeze, Diesel fuel and allied products, etc.	Fluid delivery max 14 l/min for short and medium distances (40/50 metres), at medium pressure (max 25 bar)	Pump series 3:1/14 Ratio 3:1 relative capacity 14 l/min see page 74
Medium and high viscosity fluids such as: engine oil, gearbox oil (SAE 15/140) hydraulic fluid, antifreeze, Diesel fuel and allied products, etc.	Fluid delivery max 18 l/min for medium and long distances (150/200 m.), at medium pressure (max 40 bar) suitable for systems	Pump series 5:1/18 Ratio 5:1 relative capacity 18 l/min see page 75
Medium and high viscosity grease.	Greasing for short and long distances at high pressure (max 400 bar)	Pump series 50:1 Ratio 50:1 relative capacity 1500 g/min see page 166
Medium and high viscosity grease.	Greasing for long distances at high pressure (max 500 bar) suitable for systems	Pump series 60:1 Ratio 60:1 relative capacity 1900 g/min see page 167

In the series of pumps chosen for your use, you can find the pump having the appropriate dimensions for the specific application.

PUMP SERIES 3:1/14

Ratio 3:1
Capacity 14 lt/min

PUMP SERIES 5:1/18

Ratio 5:1
Capacity 18 lt/min

PUMP SERIES 50:1

Ratio 50:1
Capacity 1500 g/min

PUMP SERIES 60:1

Ratio 60:1
Capacity 1900 g/min

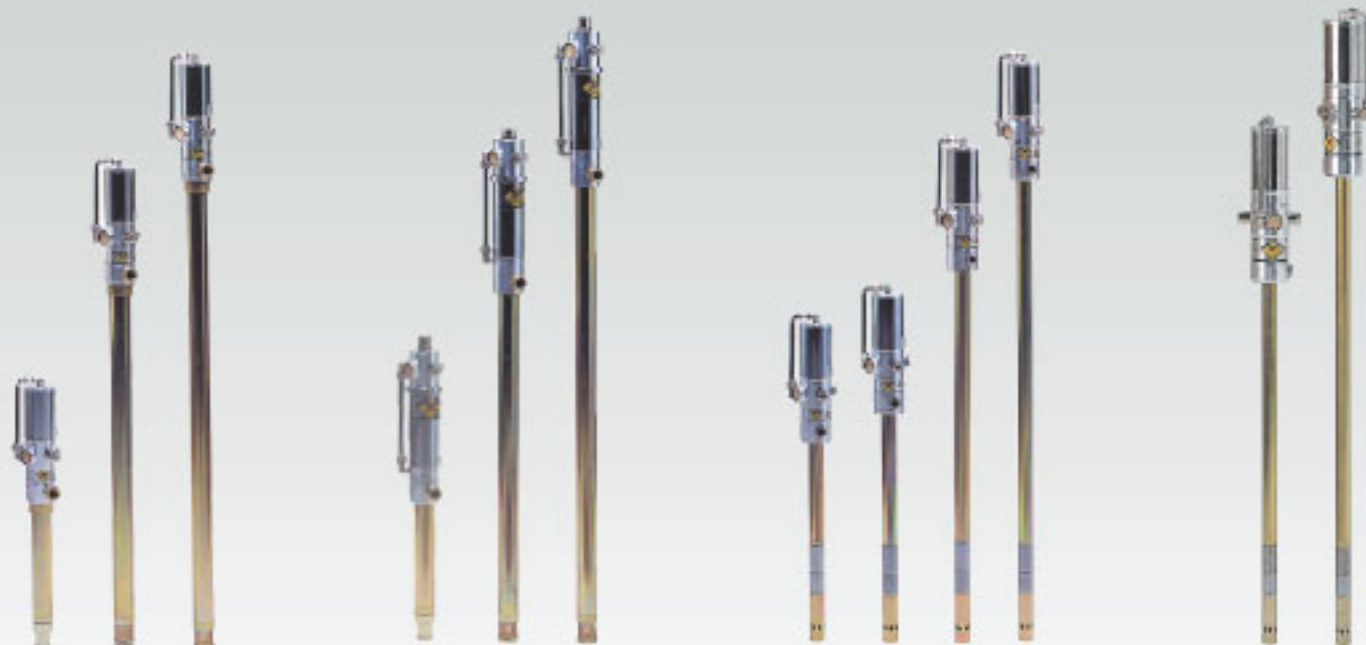

In addition to proposing a range of pumps, RAASM also offers a wide range of kits complete with accessories in many configurations according to the various requirements of use.

All the kits are given on the pages following the presentation of the pumps to which they belong.

The kits are configured according to the size of the drums, and their use: reservoir or tank, wall-mounted or with drum, with and without litre-counter, etc.



However, if the customer wishes to compose a more personalized solution for a specific use, there is also a whole range of accessories suitable for the chosen pump.

The application of the pumps to fixed systems requires attention, not only regarding the choice of pump but also regarding design of the system and coupling of all the accessories. In this respect, see the **indications for systems** given on page 56.

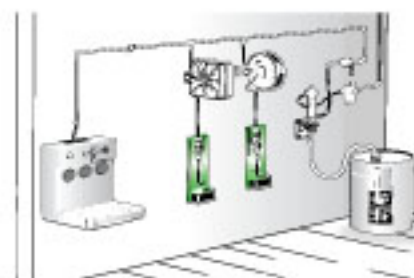

To gain overall knowledge of the pumps, we recommend also consulting the technical specifications given below:

- **Self-lubricating motor** page 48
- **Requires or does not require lubricator** page 49
- **Single- and double-acting** page 50
- **Advantages of double-action** page 51
- **Compression ratio** page 52
- **Capacity (head)** page 53
- **Suction distance** page 54
- **Indicative capacities for system.** page 55



The motors of RAASM pumps are built with self-lubricating materials.

Air distributor unit with all parts designed in self-lubricating material

Shaft guide box in self-lubricating material

Double reverser equalizer in self-lubricating material

Air inlet filter to block any impurities which could damage the motor

Air outlet silencer with 81 dB noise level

Motor piston with double lip seal and self-lubricating guide rings

Self-lubricating double-lip reverser shaft

Motor shaft in self-lubricating material with antiwear and anticorrosion treatment

Set of double-lip seals separating air motor from the oil pump.

Shaft guide in self-lubricating and anti-abrasion Teflon

Suction piston formed of a double-lip seal

Guide in self-lubricating Teflon.

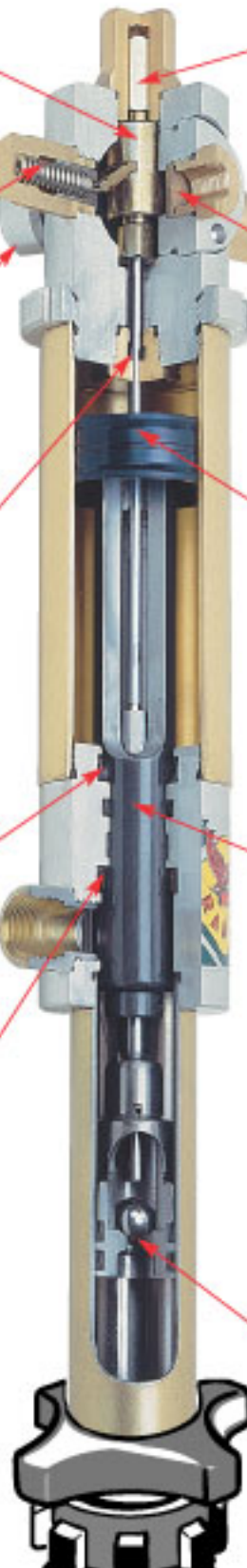

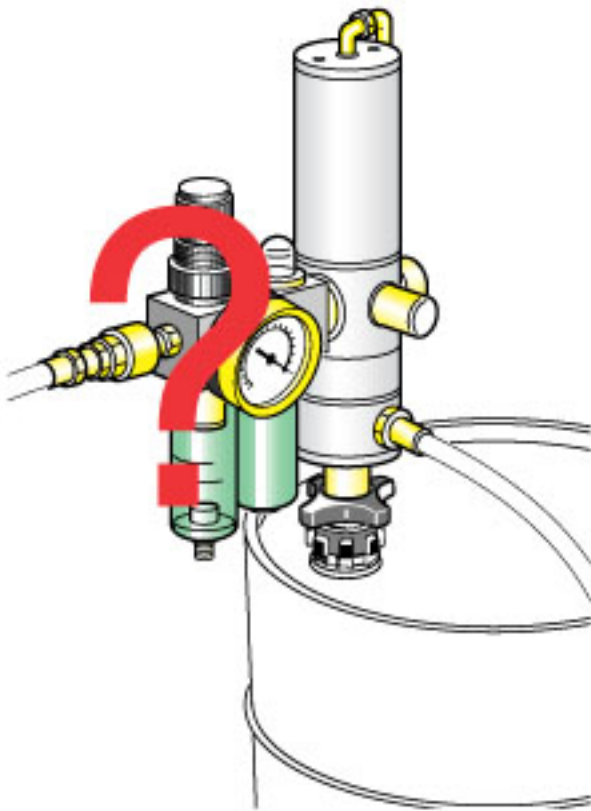

RAASM pumps are designed with self-lubricating materials.

The air feeding the pump must always be free of condensation.

In the mobile wheel-mounted kits, used in the workplace, it is best not to apply a lubricator to the pump because it would introduce the "atomized" lubricant into the workplace air. However, if the pump is installed in a protected place away from operators, application of the lubricator will guarantee longer-lasting efficiency.

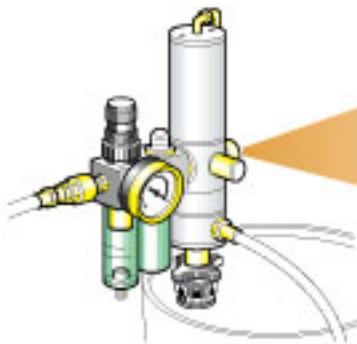

Air with atomized lubricant

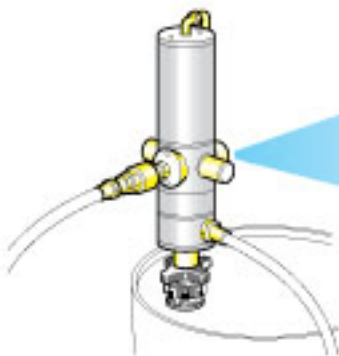

Clean air



Principle of SINGLE-ACTING pump

Pumping piston upstroke

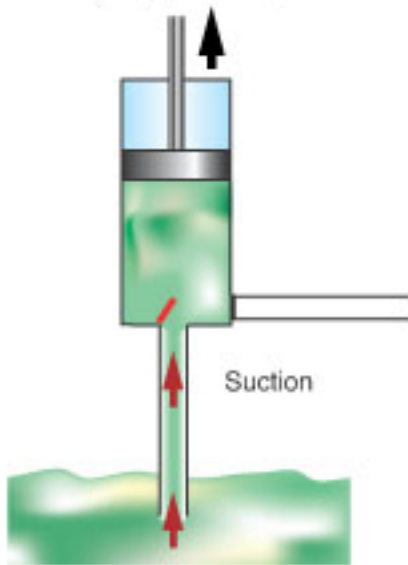

Pumping piston downstroke

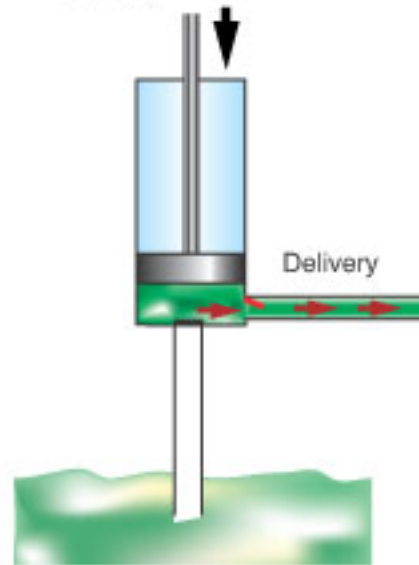

In a single-acting pump, the pumped product comes out during one of the two piston strokes making up a pumping cycle.

Principle of DOUBLE-ACTING pump

Pumping piston upstroke

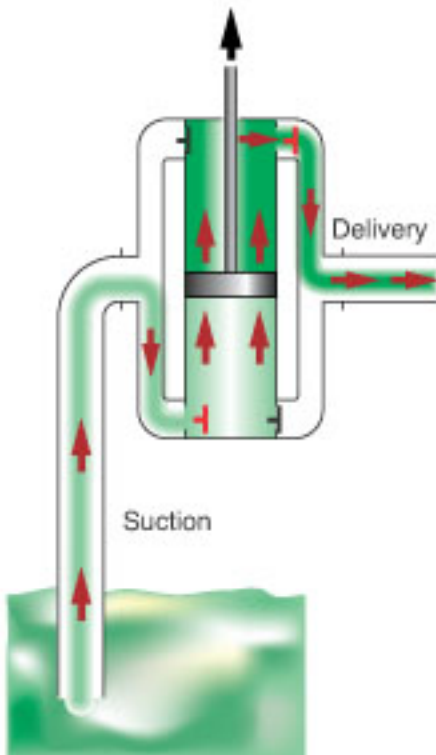

Pumping piston downstroke

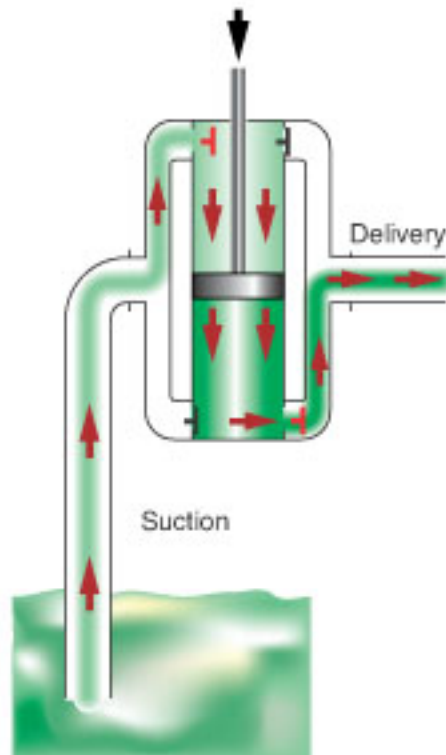

In a double-acting pump the pumping piston delivers the fluid in both alternating motions (upstroke and downstroke).

A double-acting pump delivers the fluid in an **even and non-pulsating** manner.

The mechanisms for obtaining a double-acting pump are numerous.



There are many technical solutions for obtaining a reciprocating double-acting pump.

The double-action of RAASM pumps has been obtained with solutions that have simplified the very mechanism of the pump, ensuring that delivery of the fluid in both directions (up and down) occurs only through the difference in volume between the diameters of pumping piston (A) and pump shaft (B).

On the **upstroke**, delivery is caused by the **pumping piston (A)**.

On the **downstroke**, it is caused by the **difference in volume between the diameter of the motor shaft (B) and the diameter of pumping piston (A)**.

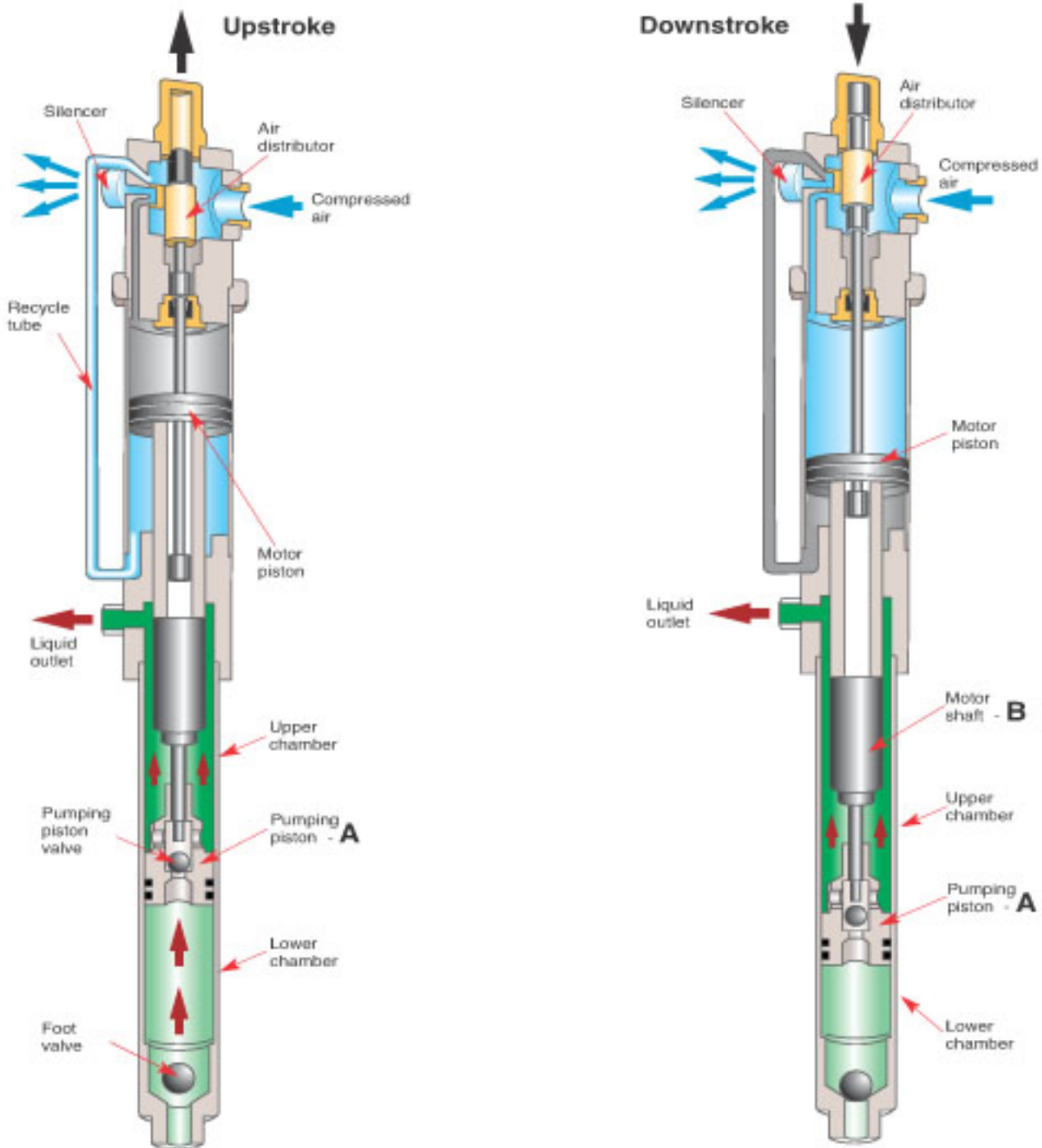

In addition to guaranteeing regular delivery of the fluid, this solution offers the further advantage of having fewer parts inside the pump. This means less wear plus greater and longer reliability.



Pump compression ratio is taken as the direct ratio existing between the pressure of compressed air feeding the pump and the pressure at which the pumped product comes out.

Normally, this compression ratio is obtained by the difference in diameter between **air motor piston A** and **liquid pumping piston B**.

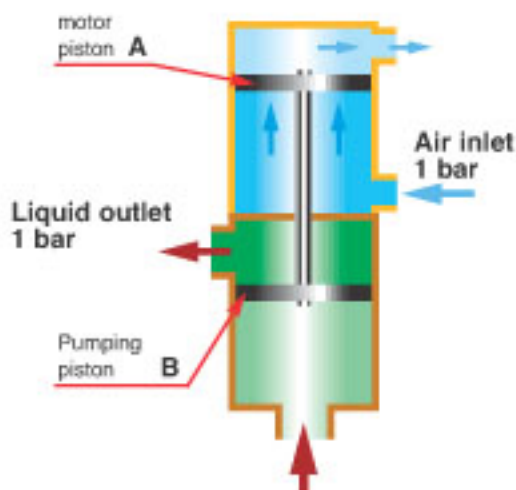

Ratio 1:1 for transfer

E.g. oil pump art. 33094 Ratio 1:1

air piston \varnothing 60 fed at **1 bar**
pumping piston \varnothing 60 delivers oil at **1 bar**.

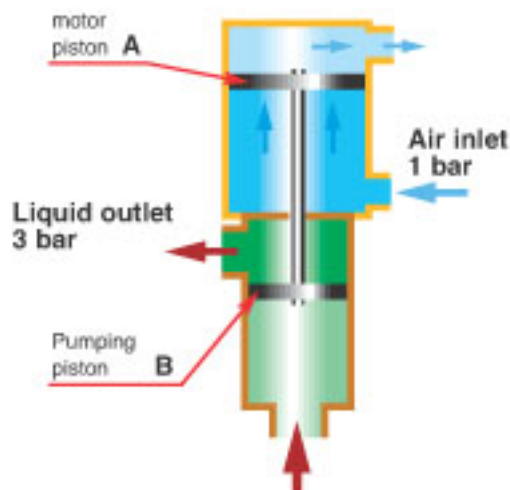

Ratio 3:1 for short range distribution

E.g. oil pump art. 35194 Ratio 3:1

air piston \varnothing 60 fed at **1 bar**
pumping piston \varnothing 38 delivers oil at **3 bar**.

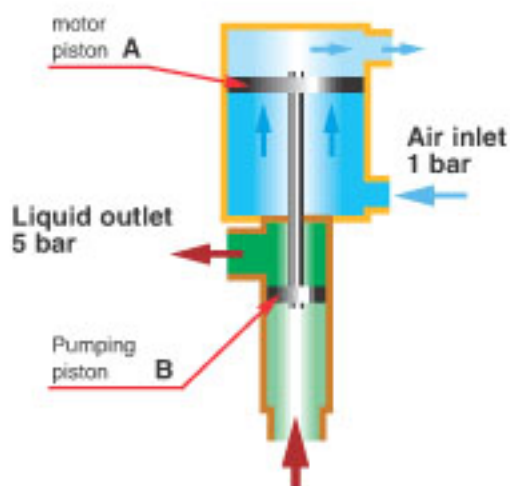

Ratio 5:1 for dispensing liquids of higher viscosity and at longer distances

E.g. oil pump art. 36094 Ratio 5:1

air piston \varnothing 60 fed at **1 bar**
pumping piston \varnothing 28,5 delivers oil at **5 bar**.

It can be noted that the smaller the size of the pumping piston compared to the air motor piston, the greater the pressure of liquid delivered, but the lower the amount of liquid delivered (capacity). For example, in the grease pump with Ratio 50:1, where the diameter of the motor piston is 14.5 mm, the pressure of grease coming out is 50 times higher than the pressure of the air feeding it.

The **capacity** of a reciprocating pump indicates **the quantity of fluid it delivers**.

The **capacity** of a pump is read in two ways:

- **Relative capacity**
- **Real capacity.**

The **'relative'** capacity or **'indicative'** capacity was obtained by laboratory testing under the following conditions:

- pump operated at 6 bar
- using motor oil SAE 30
- a room temperature (16-18°C)
- with free outlet, i.e. without any connection, delivery tube or gun connected to the pump.

The **'real'** capacity, i.e. **'the real delivery quantity'**, in certain applications and combinations, varies according to:

- type of compression ratio (see page 52);
- viscosity and temperature of the fluid;
- transfer with one delivery tube only;
- centralized systems with one or more delivery points;
- height and length of system both in suction and in delivery;
- type of connections and accessories to complete the system.
- single- or double-acting pump (see page 50 - 51);
- pressure of air feeding the pump;
- delivery tube and gun for distribution near the drum
- size of delivery tube;

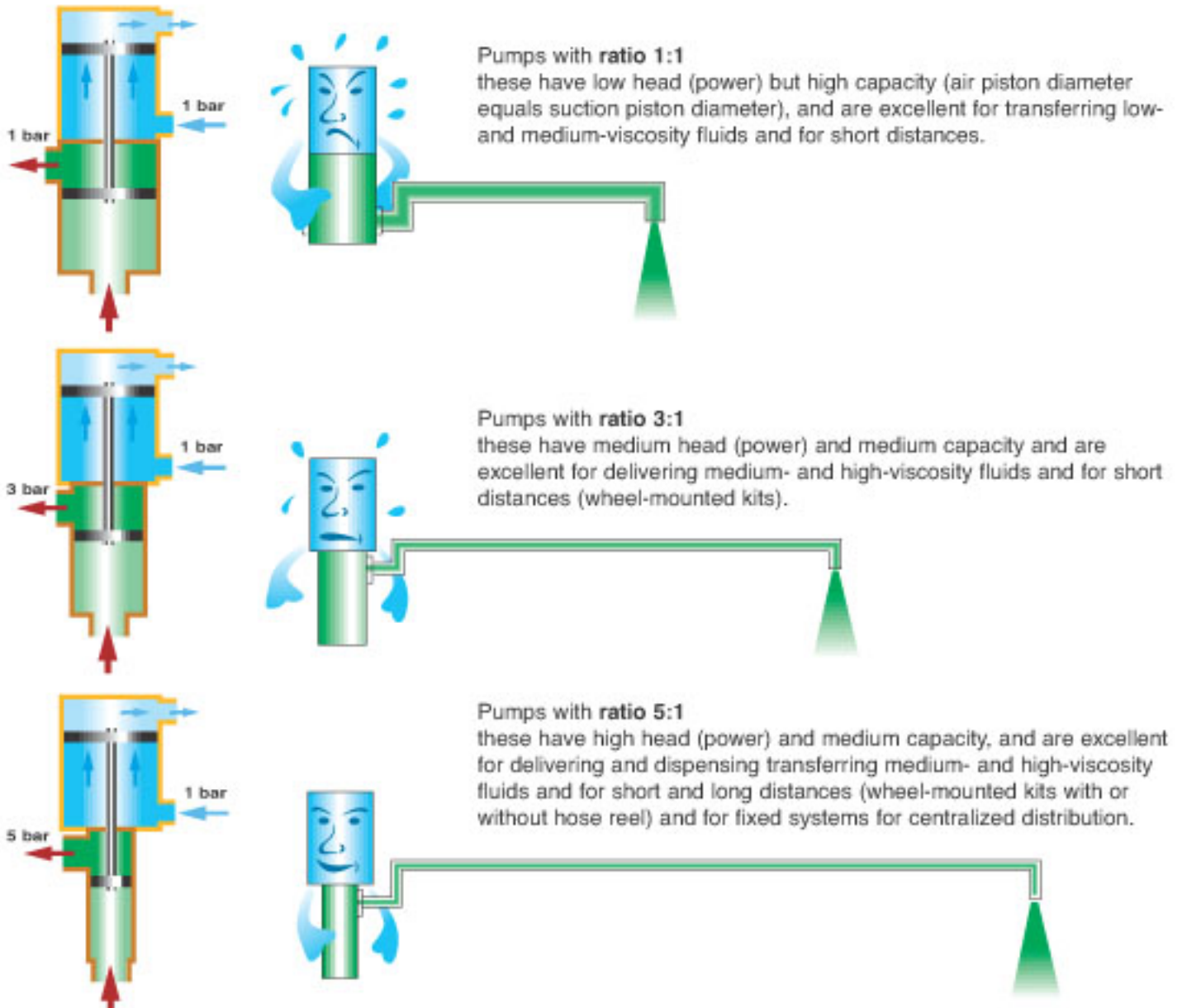

When choosing a pump, however, the relative capacity (indicative capacity) is taken into consideration, as shown on page 46.



The **suction capacity** of a pump is a rather complex technical concept and difficult to explain, because it concerns various parameters, including:

- atmospheric pressure
- specific weight of the liquid
- viscosity of the liquid
- evaporation of the liquid
- size of the suction tube, etc.

All these factors affect the suction possibility and capacity of a pump, because they all depend on precise physical laws which cannot be avoided.

Therefore, a pump must **be installed** as close as possible to the suction point; in fact, if a certain distance is exceeded the efficiency and functionality of the pump itself is seriously affected.

In order to render this concept clearer, try to imagine how hard it would be to drink your favourite drink, just served, with the glass on the floor and you on the table.

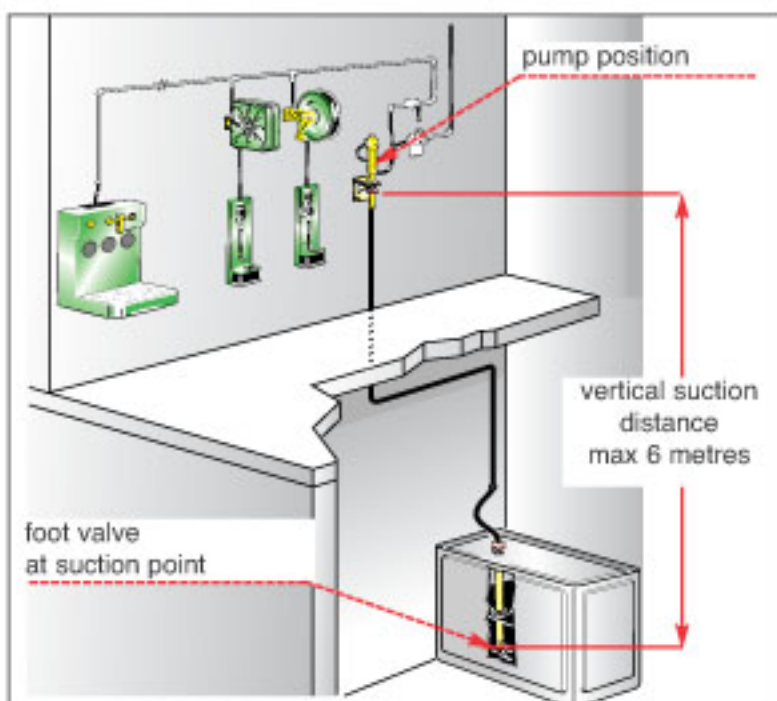

To correctly install a pump that ensures 'RELAXED' and long-lasting operation, just follow the simple instructions given below:



INDICATIVE SUCTION DISTANCES WHEN INSTALLING A PUMP

Firstly, when installing a pump, it is essential to apply a **foot valve** at the point of suction.

The **vertical distance** between the pump and the foot valve must not be more than **6 metres**.

The **horizontal distance** between the pump and the foot valve must not be more than **20 metres**.

If the vertical and horizontal distances must be taken into consideration when installing a pump, these must also be proportionally reduced.



The 'real' or 'indicative' capacity was obtained by means of laboratory testing under the following conditions:

- for pumps ratio: 5:1 e 3:1 =
pump with air feed at 6 bar; temperature 15° C; with oil SAE 30
- for pumps ratio 50:1 e 60:1 =
pump with air feed at 6 bar; temperature 15° C; with grease NLGI - 1

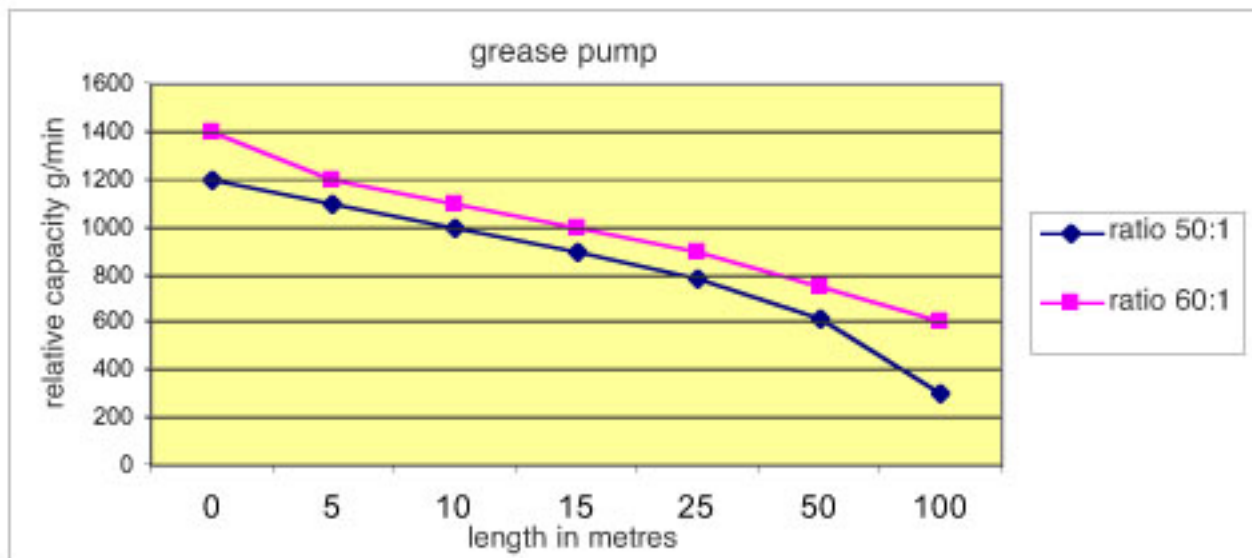
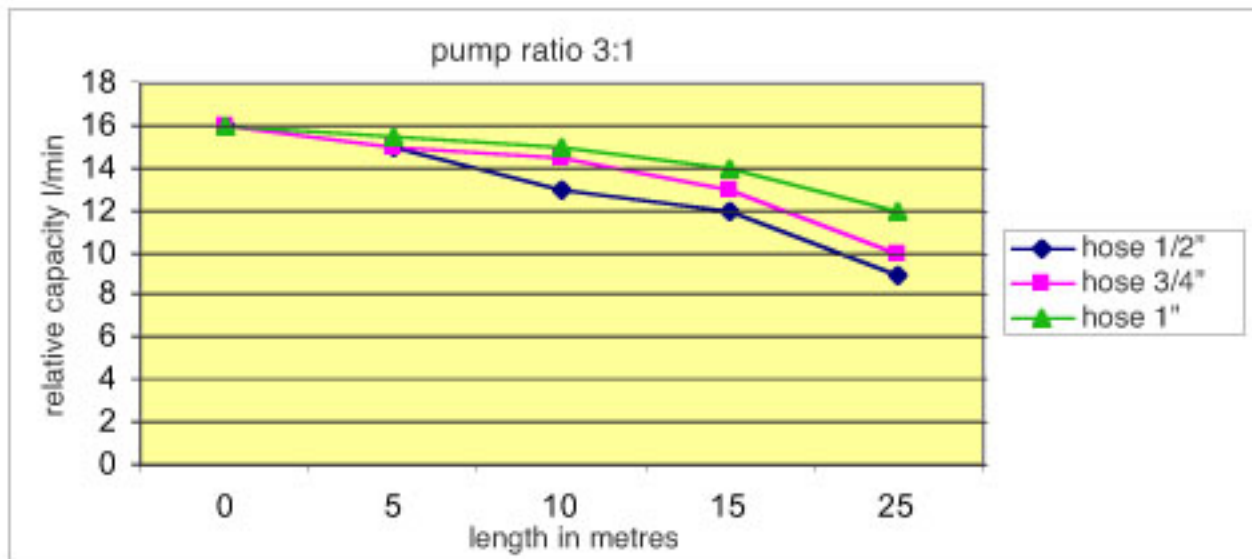
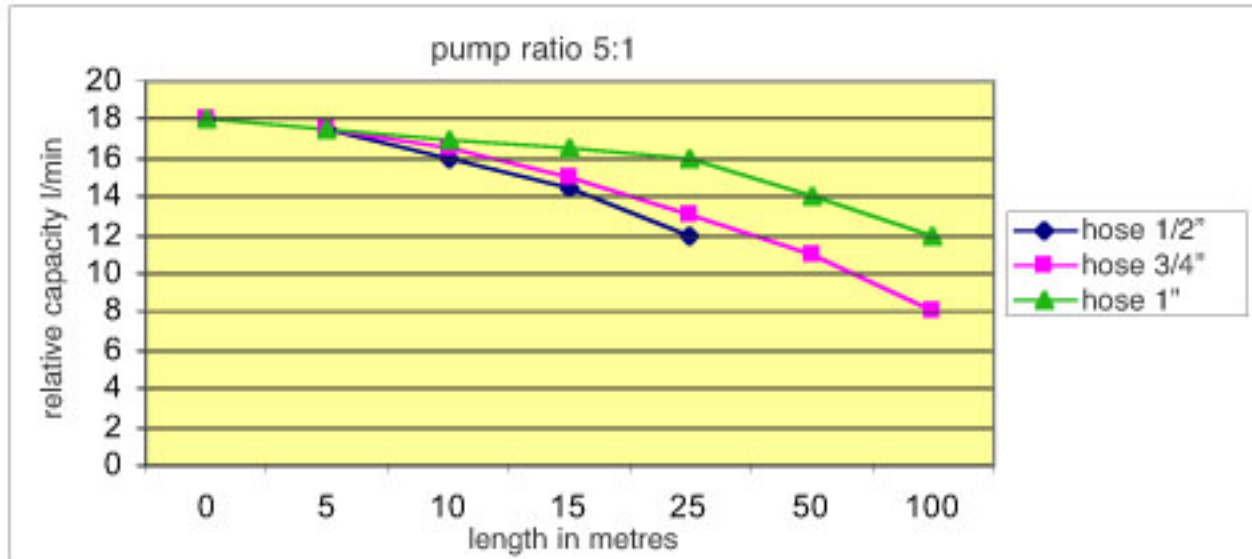



Partial view of a system of medium and large dimensions for dispensing oils and allied products.

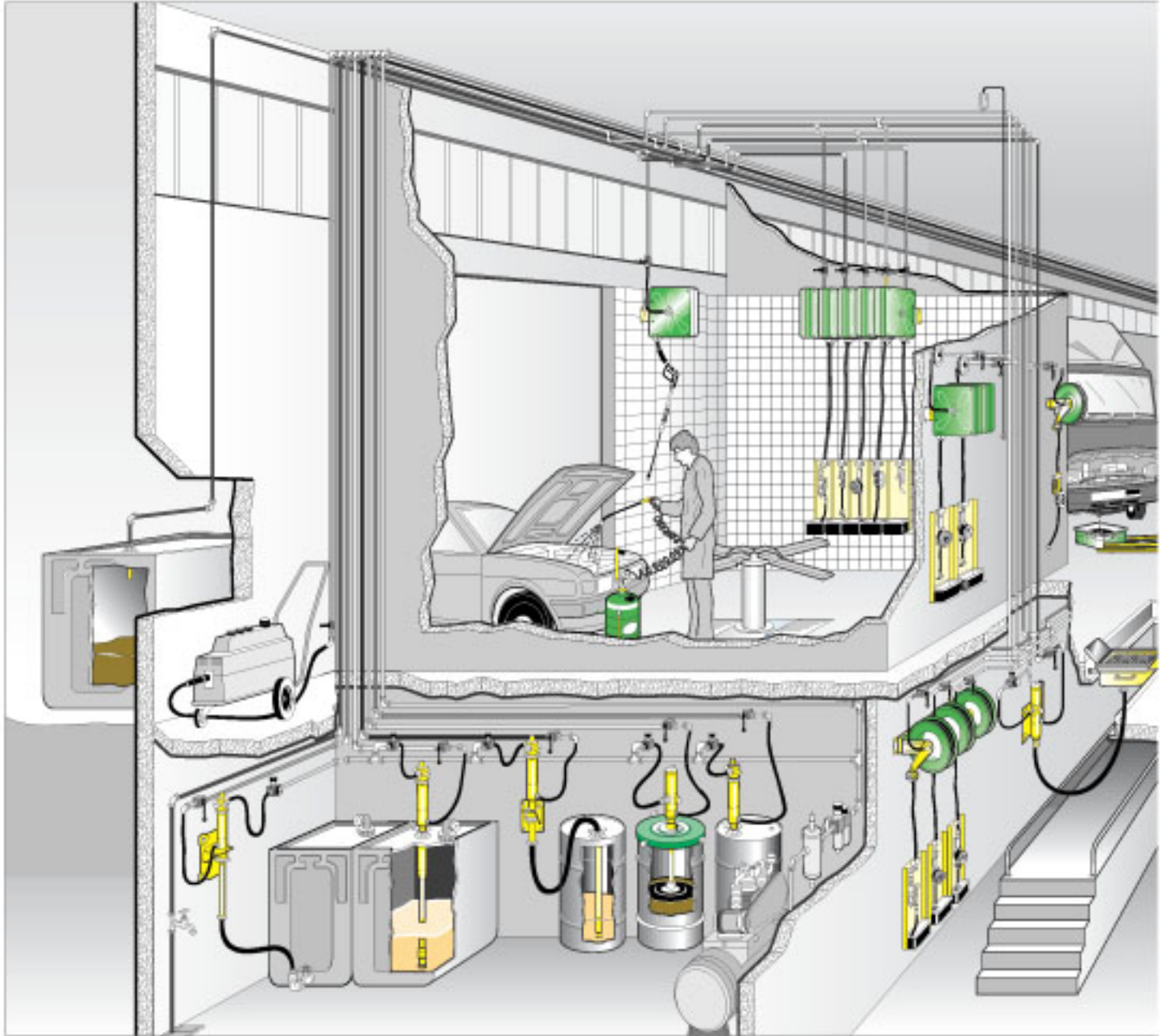

This type of system includes storage and distributions systems for many fluids, including various types of oil, grease, antifreeze, depleted oil, which can require one or more delivery points at various distances from the storage point.

For the purpose of correct and efficient planning, it is therefore essential to consider each distribution line as a separate system.

To correctly plan this distribution line (or this system) so that it works efficiently, it is all-important to understand and consider the following details:

- **type of product** to be delivered
- **density and temperature** (a temperature reduction determines higher density of the fluid)
- **distance** between pump and serviced point
- the **number** of fluid distribution **points**
- the **quantity of fluid** required per minute for each service point
- the **horizontal distance** between pump and delivery points
- the **vertical distance** between the delivery pump and delivery points
- the **vertical distance and the horizontal distance** between the delivery pump and delivery points (in this case, a precise physical law must be respected).

With these fundamental elements and additional specific information given below, the correct dimensions and lengths of the distribution pipe work can be established, to easily choose the best RAASM articles for the type of application required.

Example:

- | | |
|---|-------------------|
| - dimensions and lengths of distribution pipe work | see page 58 |
| - accessories and connections for completing the system | see page 59 |
| - type of pump, i.e. for tank, drum, or wall-mounted. | see page 60 |
| - type of delivery point, i.e. type of hose reel or oil bar | see page 93 - 209 |
| - type of gun for delivery with or without meter | see page 87/93 |
| - etc.; | |

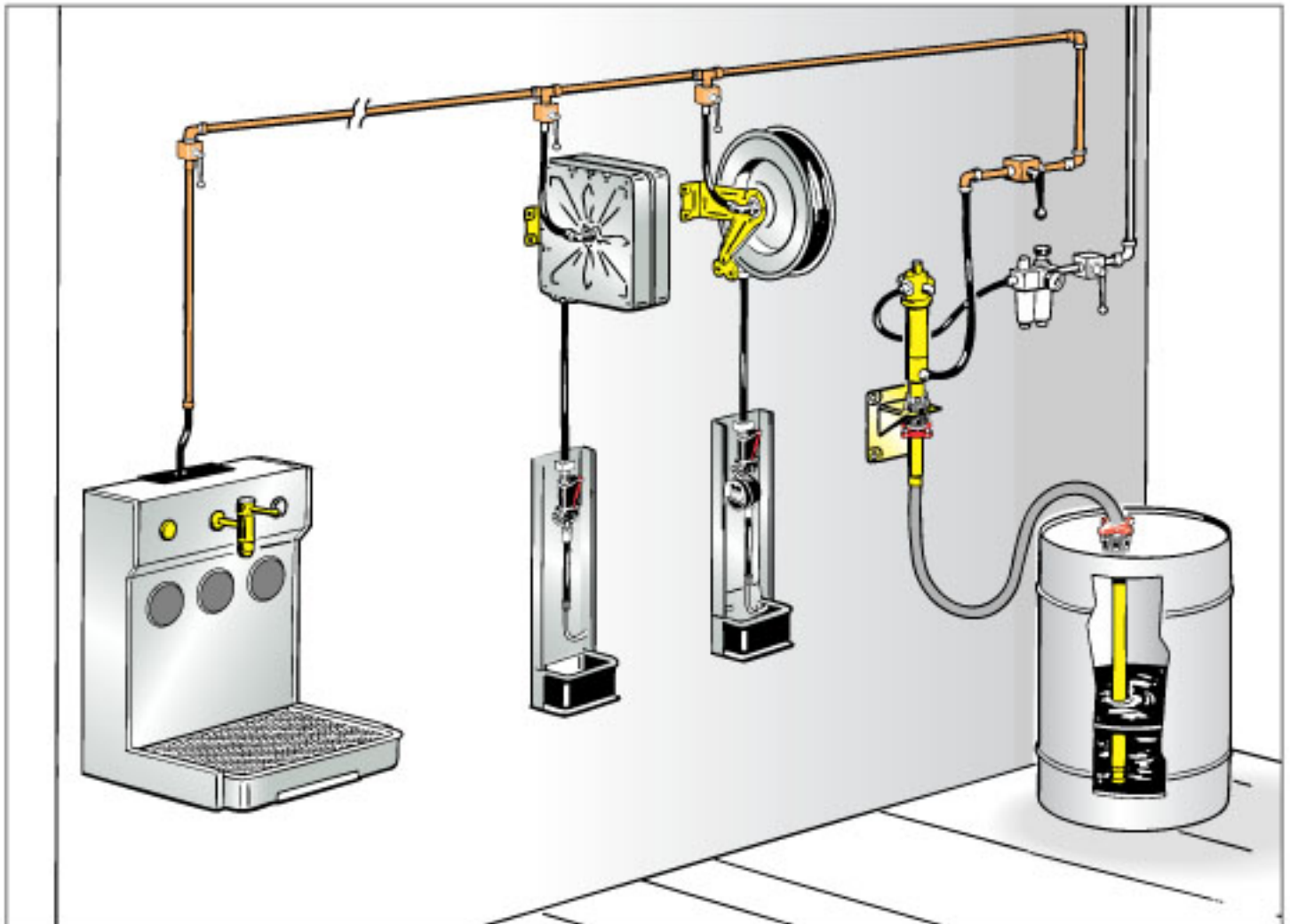

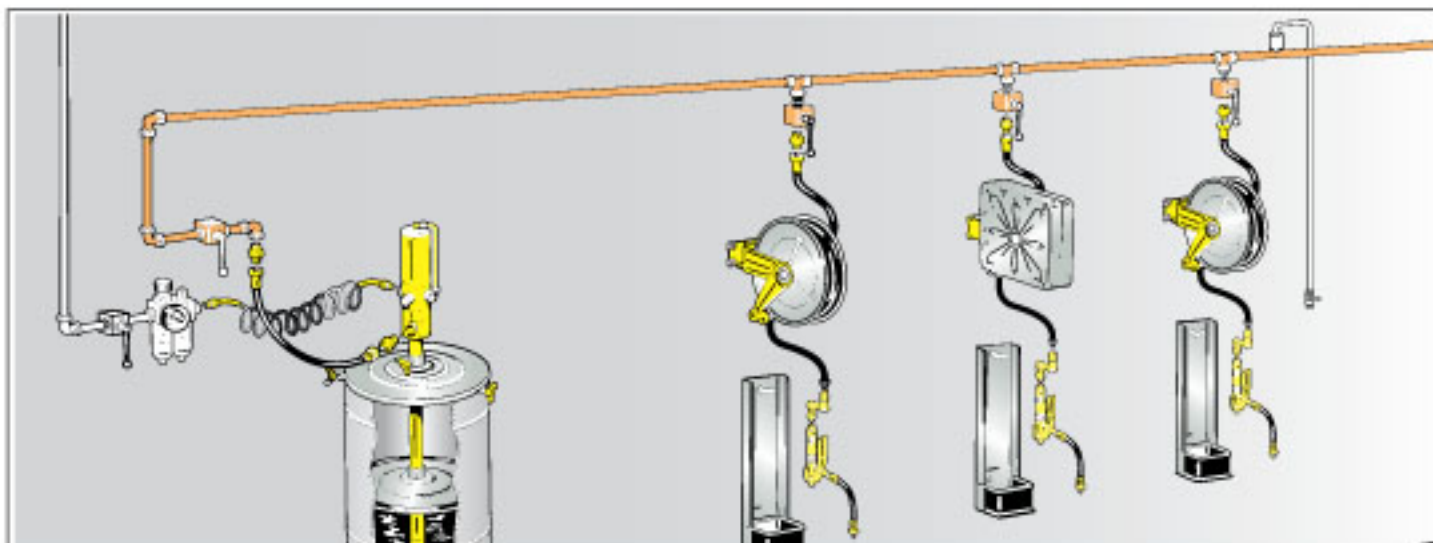

According to European Norms, high-pressure fluid distribution systems must not exceed 400 bar.

All the grease distribution lines must be prepared with tubing (in steel, rubber, ...) for high pressures at 600 bar, and must be smooth and seamless, with connections possibly having an inside diameter greater than the tube itself, so as not to create any constrictions.

Main grease line - Tube characteristics -

0 - 200 m minimum inside diameter: 1/2" (ϕ 15 mm)

Discharge minimum inside diameter: 3/8" (ϕ 10 mm)

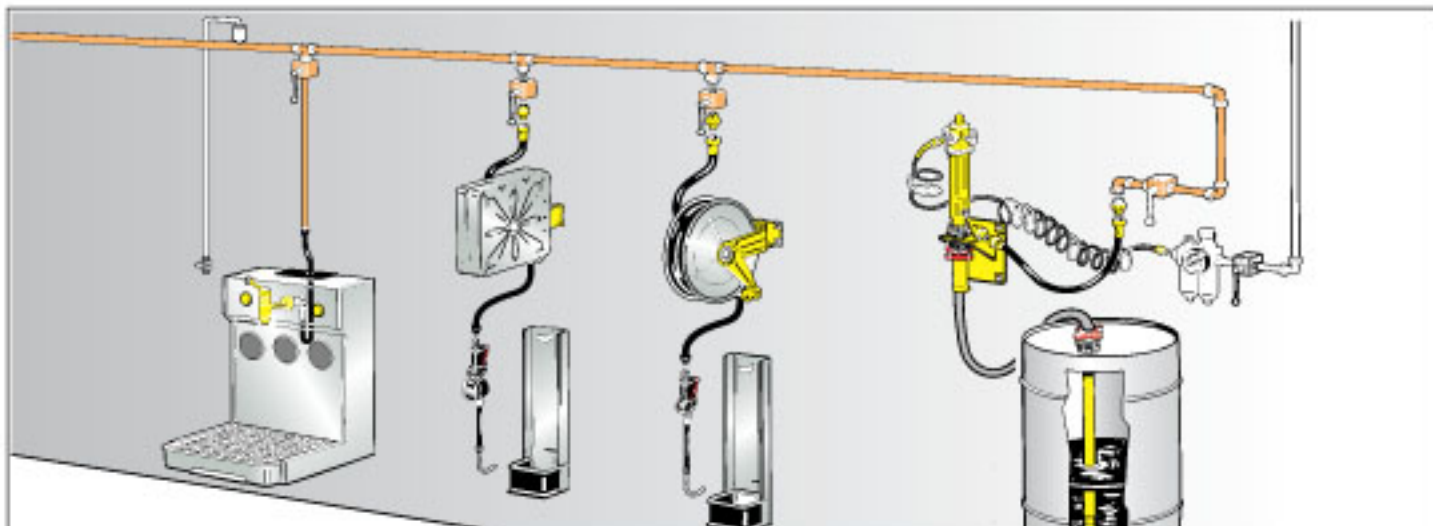

All the distribution lines for oils and allied products, antifreeze, etc. must be prepared with tubing (in steel, rubber,...) for high pressures at 60 bar, and must be smooth and seamless, with connections possibly having an inside diameter greater than the tube itself, so as not to create any constrictions.

Main motor oil line - Tube characteristics -

0 - 15 m minimum inside diameter 3/4" (ϕ 19 mm)

16 - 50 m minimum inside diameter 1" (ϕ 25 mm)

51 - 100 m minimum inside diameter 1.1/4" (ϕ 30 mm)

101 - 200 m minimum inside diameter 1.1/2" (ϕ 38 mm)

Main gear oil line - Tube characteristics -

0 - 15 m minimum inside diameter 1" (ϕ 25 mm)

16 - 50 m minimum inside diameter 1.1/2" (ϕ 38 mm)

51 - 250 m minimum inside diameter 2" (ϕ 50 mm)

Discharge: inside diameter 3/4" (ϕ 19 mm)

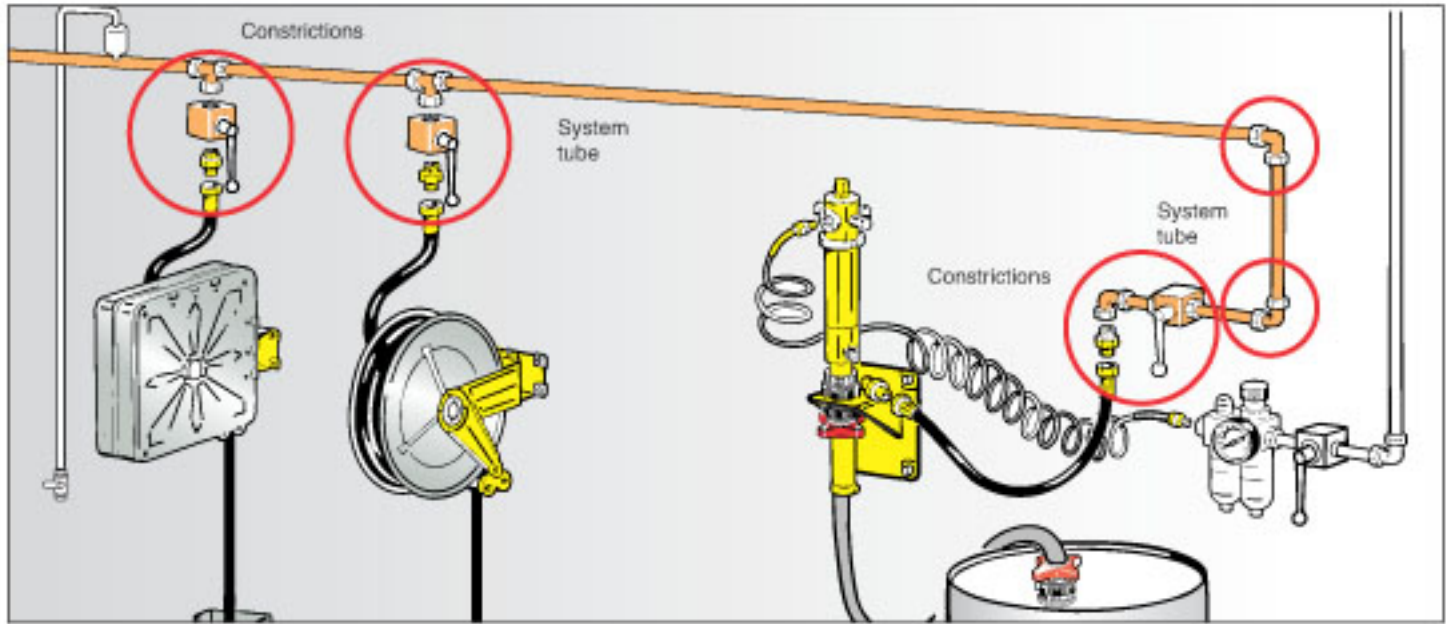

When installing a system for distributing fluids, not only is the choice of pipe work all-important, but it is also essential to:

- connect the ball cocks (taps) at the start of each line, at every branch or delivery point (for example: before the connection to the hose reel);
- apply an air bleeding system at the highest point of a line;
- apply a condensation filter for discharge at the start of the air line feeding the pump.

Particular attention must be paid in choosing unions, branches, bends, and anything that can cause a constriction, because these small 'distractions' could negatively affect the efficiency of the entire system.

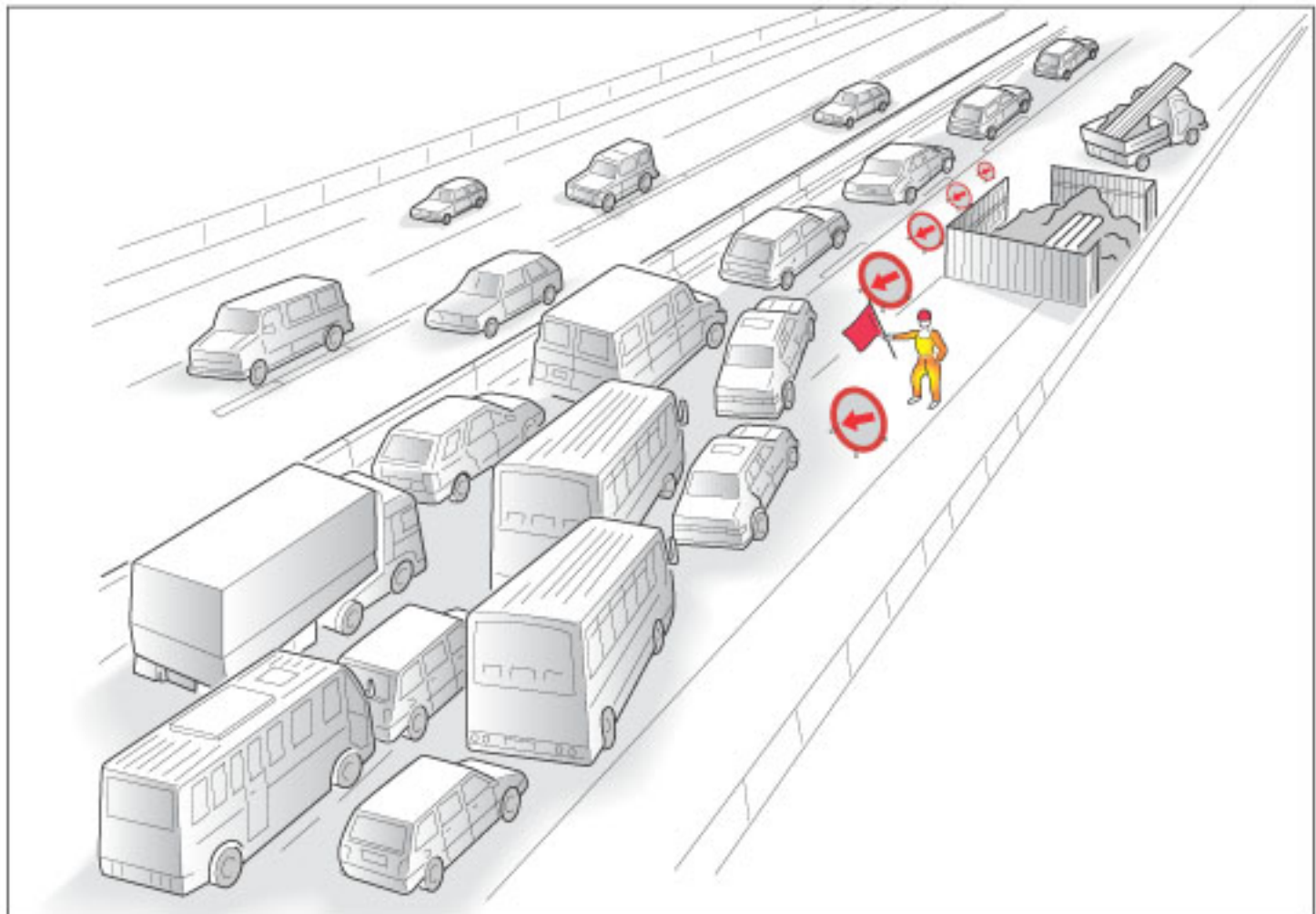

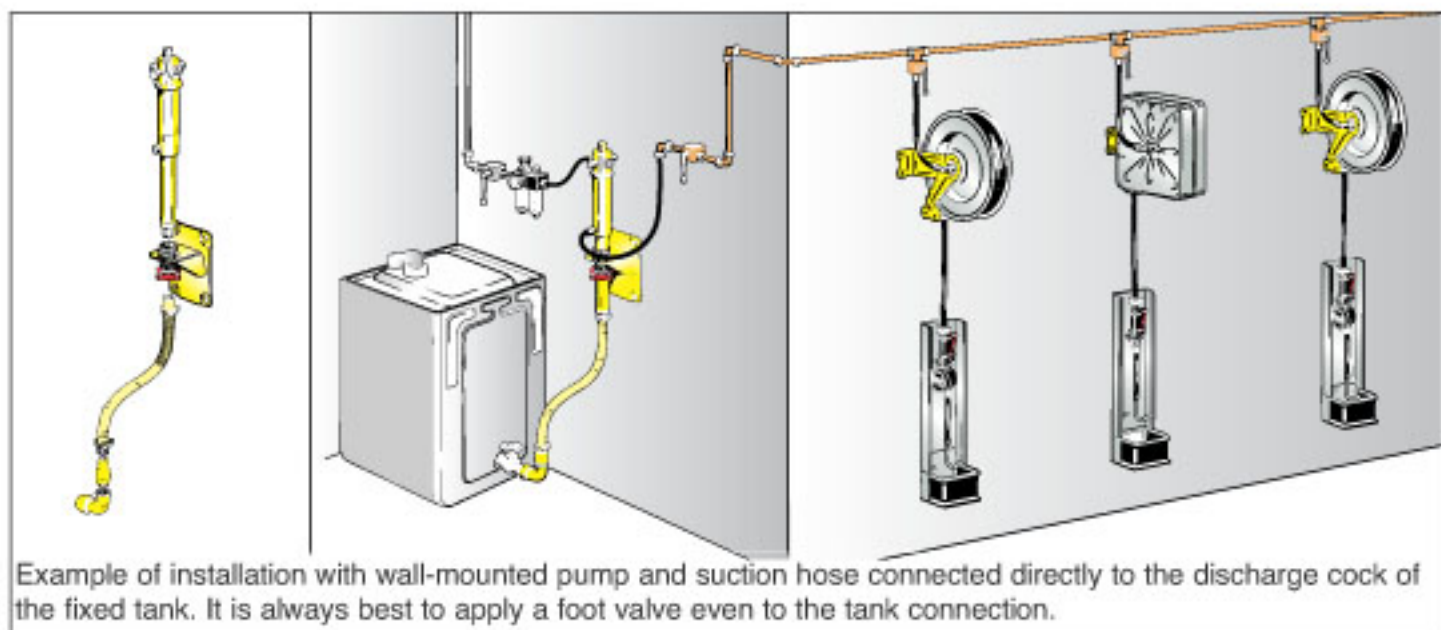
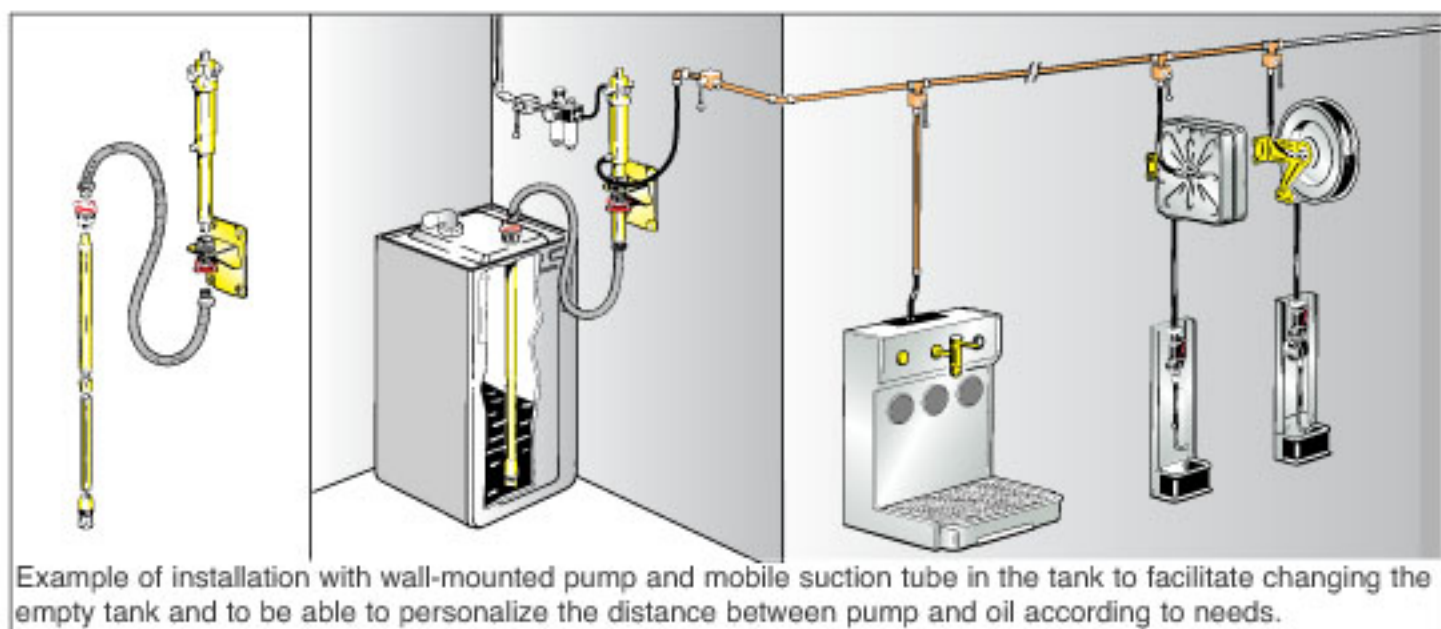
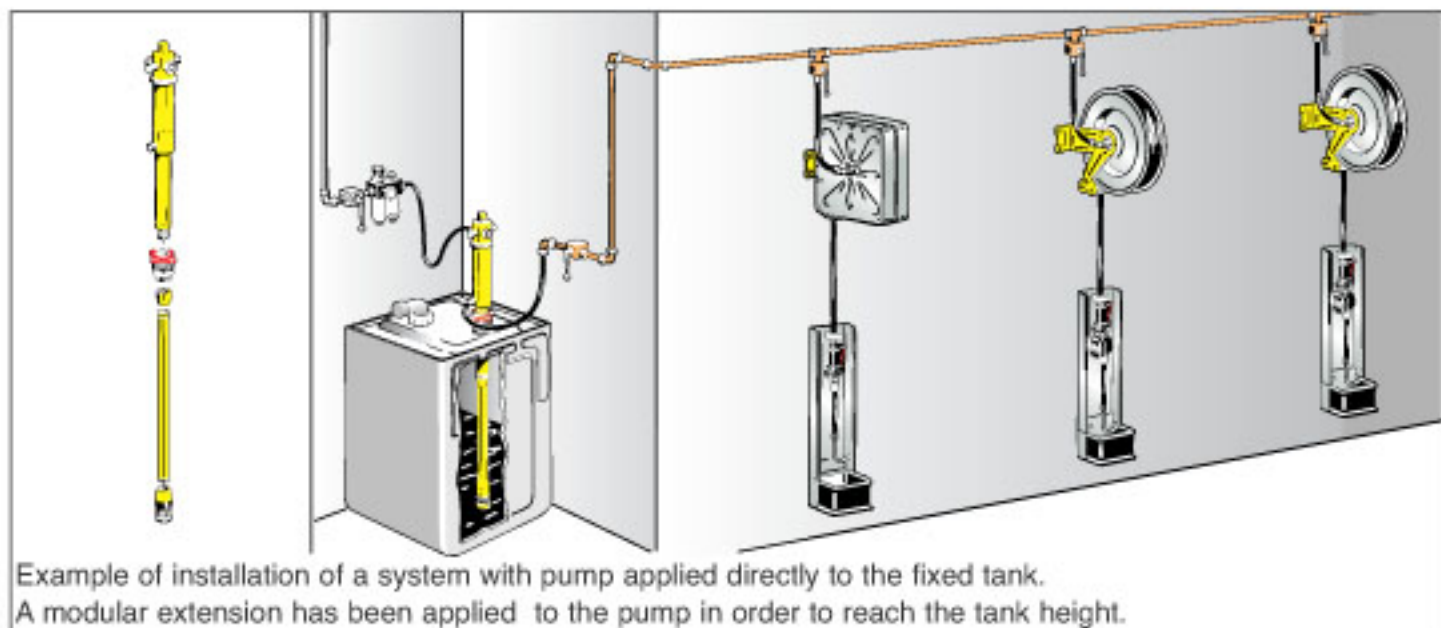

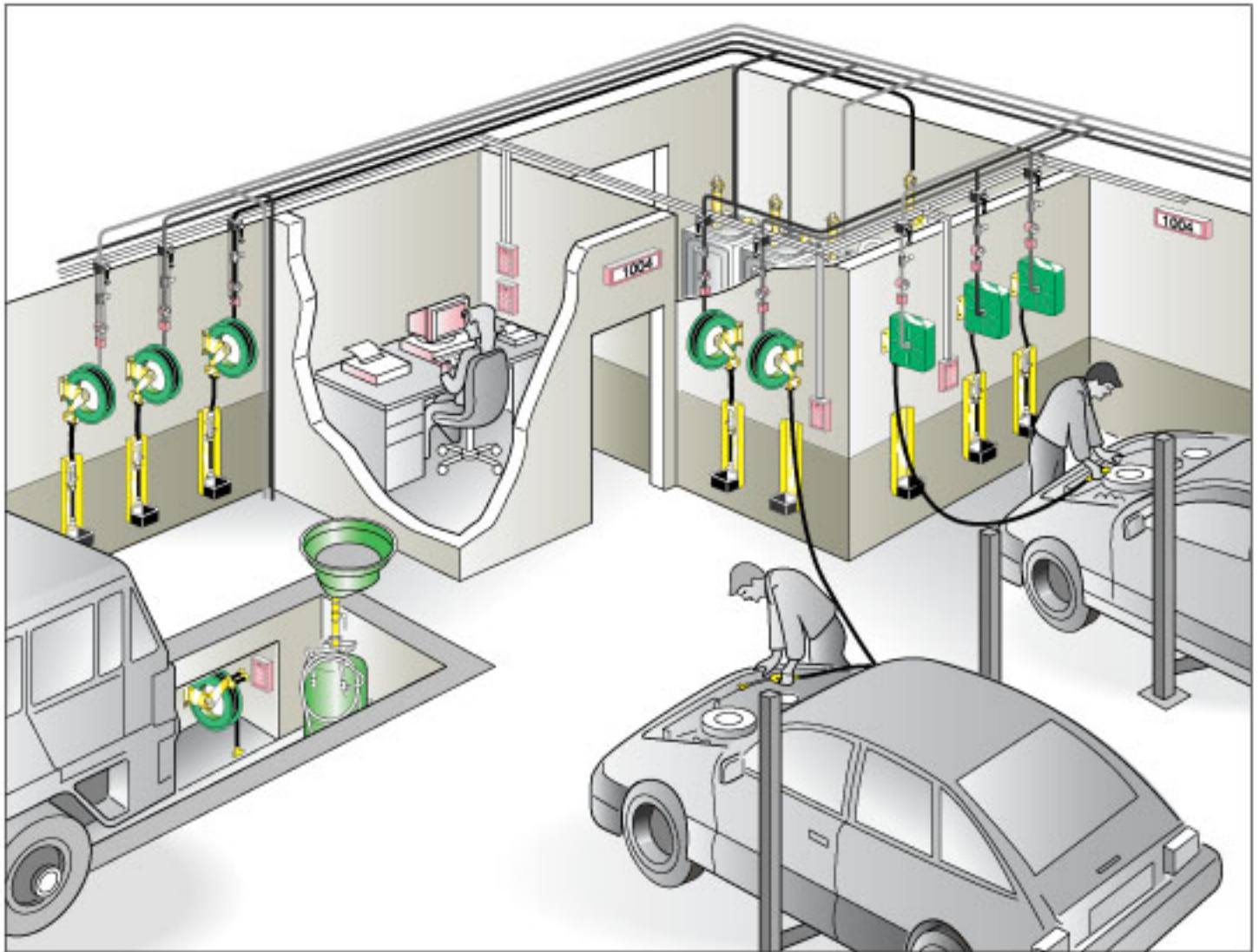

COMPUTERIZED FLUID MANAGEMENT SYSTEM

The computerized management system can be used both by small garages as well as by large service centres when different types of oil and antifreeze, stored in centralized tanks in a single room, are to be distributed by several distributors, situated in various points of the workshop.

Performance and advantages:

- easy to use by operators
- delivery allowed by authorized personnel only
- preselection of quantity to be delivered
- control of takings with elimination of any waste
- efficient control of fluid stocks
- safety of recorded data for subsequent invoicing.

Being a unit assembly and modular, the computerized management system is excellent for a multitude of uses, ranging from a simple preselection check of the quantity of fluid delivery (with or without receipt), to direct connection with the refinery that actually produces the fluids.

