



# Stenhøj Mistral 20 & H 25

## Single post surface-mounted lifts

The program consists of an electro-mechanical and an electro-hydraulic version – Mistral 20 and Mistral H 25 respectively. The Mistral lifts are especially suitable for body work and general repairs; besides which Mistral H 25 is also suitable for wash and underbody sealing. The Mistral lifts have lifting capacities of 2 and 2.5 t respectively.

### Features:

Top safety:

- automatic arm lock system
- motor IP54 / control unit IP65

### Mistral 20

- nut breakage system
- obstruction system

### Mistral H 25

- emergency stop valve
- mechanical ratchet system for parking

Very flexible

- good access to sides of vehicle
- vehicle can be placed in more than one way on the lift
- takes up very little room in the workshop
- available with either screw (S) or combi (C) pads

Lifting height

- S-models: 2120 mm
- C-models: 2215 mm

### Mistral 20 & H 25

- are like all other Stenhøj lifts CE-approved



## STENHØJ

DK-7150 Barrit

Phone: +45 7682 1330

Fax: +45 7682 1331

[www.stenhøj.dk](http://www.stenhøj.dk)

E-mail: [autolift@stenhøj.dk](mailto:autolift@stenhøj.dk)

# Stenhøj Mistral 20 & H 25

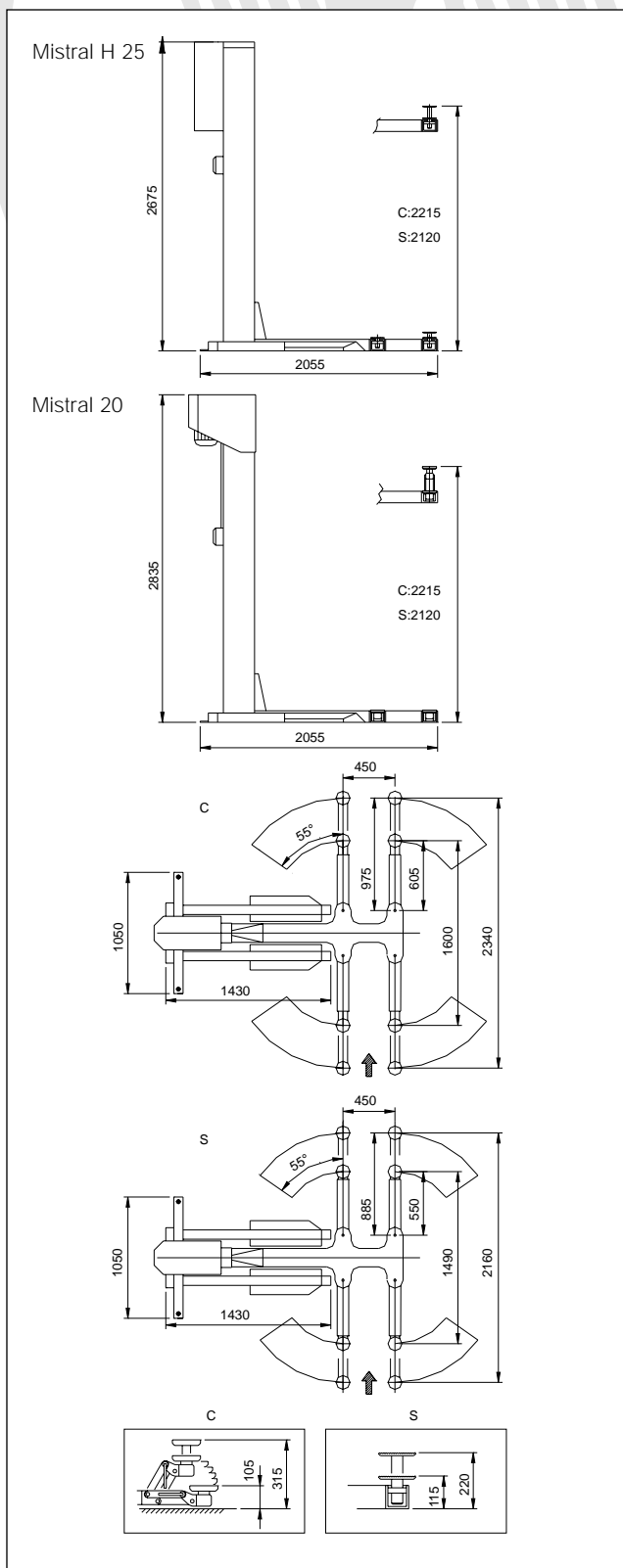

Mistral 20 S

Technical data:	Mistral 20	Mistral H 25
Lifting capacity:	2000 kg	2500 kg
Lifting time:	45 sec.	27 sec.
Motor:	2.2 kW	1.5 kW

#### Optional extras:

Pad sets for C-versions, lighting set. Expansion bolts are included in the delivery of a Mistral lift.

#### Corrosion-proof surface treatment

All Stenhøj lifts are led through a sling purifying plant (according to SA2.50 - ISO-Norm 8501-1:1988), dipped in primer, and finally led through an electro-static powder bake plant.

#### Standard colours:

Red RAL 3013  
White RAL 9002  
Special colour combinations on request.

#### Identification of a Mistral lift:

H = hydraulic. Digits (e.g.. 20) = capacity in 100 kg.  
Letters: S = screw pad, C = combi pad.

No liability accepted for specifications, which are subject to alteration.



## STENHØJ

DK-7150 Barrit  
Phone: +45 7682 1330  
Fax: +45 7682 1331  
www.stenhøj.dk  
E-mail: autolift@stenhøj.dk